

## Regulation of Harmonics

**Abstract:** Ideally, an electricity supply should show a perfectly sinusoidal voltage signal at every customer location. However, utilities often find it hard to preserve such desirable conditions for a number of reasons. The deviation of the voltage and current waveforms from sinusoidal is described in terms of the waveform distortion, often referred to as harmonic distortion.

### Introduction

This distortion can be caused by many sources including UPS back-up power supplies, fluorescent or solid state lighting and ballasts, fan speed controls, halogen lights, unfiltered dimmer switches and the A/C-D/C power supplies found in many electronic devices.

Incoming power from the utility company can also contain harmonics. This may be caused directly by the utility company or other customers served by the same substation may be introducing electrical noise into that section of the grid.

The presence of harmonics in a power supply can cause many undesirable effects upon elements of the distribution network as well as in some electrical equipment. In order to lessen these effects, certain limits have been placed upon the level of harmonics permitted to be generated by electrical equipment. This equipment has been classified by how likely they are to cause harmonics in the grid.

### Classification of equipment

Equipment can be grouped into one of 4 classes based on the following criteria as evaluated by the IEC committee members:

- Number of pieces of equipment likely to be in use
- Duration of use
- Simultaneity of use
- Power consumption
- Likely harmonic spectrum, including phase

After all the above criteria are taken into consideration equipment are classified as follows:

#### Class A

- Balanced three-phase equipment
- Household appliances, excluding equipment identified by Class D
- Tools excluding portable tools

- Dimmers for incandescent lamps
- Audio equipment
- Everything else that is not classified as B, C or D

#### Class B

- Portable tools
- Arc welding equipment which is not professional equipment

#### Class C

- Lighting equipment

#### Class D

- Personal computers and personal computer monitors
- Television receivers

Note: Class D equipment must have power level 75W up to and not exceeding 600W

The limits imposed on the harmonic content of Class C equipment (lighting equipment) are shown in Table 1 below:

Harmonic order (n)	Maximum permissible harmonic current expressed as a percentage of the input current at the fundamental frequency (%)
2	2
3	$30-\lambda^*$
5	10
7	7
9	5
$11 \leq n \leq 39$ (odd only)	3
* $\lambda$ is the circuit power factor	

**Table 1. Class C Harmonic Limits**

(The tables of the harmonic limits for the remaining classes can be found at the end of this report, along with a flowchart that helps to determine the class of any piece of electrical equipment)

The obvious question that is raised by these limits is why are some harmonics (such as the third) considered to be worse than others, and so have stricter limitations? In order to answer this question a deeper understanding of harmonics is necessary.

### Basics of Harmonic Theory

The term “harmonics” originated in the field of acoustics, where it was related to the vibration of a string or an air column at a frequency that is a multiple of the base frequency. A harmonic component in an AC power system is defined as a sinusoidal component of a periodic waveform that has a frequency equal to an integer multiple of the fundamental frequency of the system, i.e.

$$f_h = (h) \times \text{fundamental frequency}$$

where h is an integer. For example, the frequency of the fifth harmonic of a 50 Hz power supply can be calculated as:

$$f_5 = (5) \times 50\text{Hz} = 250\text{Hz}$$

The concept of harmonics is conveyed visually in Figure 1 below.

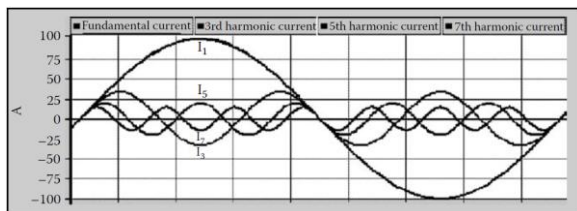

Figure 1 Sinusoidal 50 Hz Waveform and Some Harmonics

Figure 1 shows an ideal 50 Hz waveform with a peak value of 100 A, (which we will take as one per unit). Likewise, it also portrays waveforms of amplitudes 1/7, 1/5, and 1/3 per unit and frequencies seven, five, and three times the fundamental frequency, respectively. This pattern of harmonic components of decreasing amplitude with increasing harmonic order is typical in power systems. **This is why the limits placed upon higher order harmonics are more relaxed than lower order harmonics.** So, where exactly do harmonics come from?

#### Linear Loads

Harmonics do not enter the equation when dealing with linear loads. Linear loads are loads in which the current waveform matches the applied voltage

waveform. For a linear load powered by a mains supply, the current waveform will be sinusoidal.

A sine wave can be described as a function of time as follows:

$$y(t) = A \sin(\omega t + \phi)$$

where:

- A, the amplitude, is the peak deviation of the function from its center position.
- $\omega$ , the angular frequency, specifies how many oscillations occur in a unit time interval, in radians per second.
- $\phi$ , the phase, specifies where in its cycle the oscillation begins at  $t = 0$ . (Or its displacement along the x-axis)

Which means the current waveform for a linear load driven by an AC voltage can be expressed as

$$I(t) = I_{peak} \sin(\omega t + \phi)$$

#### Non-Linear Loads

Non-linear loads are loads in which the current waveform does not resemble the applied voltage waveform. This can be due to a number of reasons, such as the use of electronic switches that conduct load current for only a fraction of the power frequency period. Among the most common nonlinear loads in power systems are those containing rectifying devices like those found in power converters, power sources, uninterruptible power supplies (UPS) units, and arc devices like fluorescent lamps. Figure 2 shows an example of what a current waveform of a nonlinear load may look like.

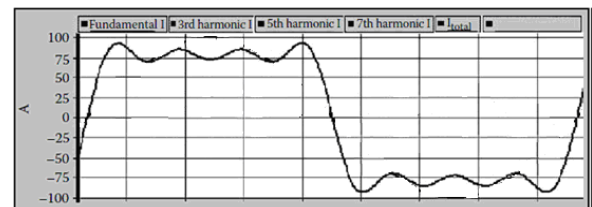
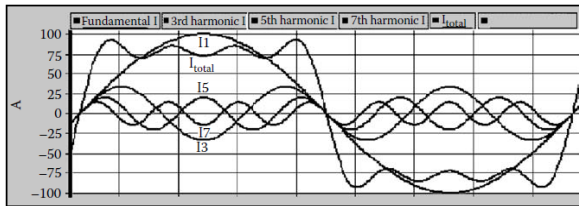

Figure 2 Distorted Waveform (Non-Sinusoidal)

Unlike a linear load, this waveform is far from sinusoidal. However, if we superimpose the harmonic waveforms seen in Figure 2 upon the fundamental....



**Figure 3 Sinusoidal Waveform Distorted by Third, Fifth and Seventh Harmonics**

We see that this distorted waveform is simply the sum of a fundamental sinusoidal waveform and its 3<sup>rd</sup>, 5<sup>th</sup> and 7<sup>th</sup> harmonics (Figure 3). The resultant distorted waveform can therefore be expressed as:

$$I_{total} = I_{1,peak} \sin(\omega t + \phi_1) + I_{3,peak} \sin(\omega t + \phi_3) + \dots + I_{5,peak} \sin(\omega t + \phi_5) + I_{7,peak} \sin(\omega t + \phi_7)$$

In fact, any periodic function where  $f(t) = f(t+T)$ , (i.e. a waveform which repeats itself) **can be expressed as the sum of its fundamental sinusoidal components and its integer multiple frequencies (harmonics)**. This is known as a Fourier Series, and so can be expressed as:

$$f(t) = c_0 + \sum_{h=1}^{\infty} c_h \sin(h\omega_0 t + \phi_h)$$

Where

- $c_0$  refers to the magnitude of the dc component of the function
- $h$  is the harmonic number
- $c_h$  is the amplitude of the harmonic component  $h$
- $\omega_0$  is the fundamental frequency
- $\theta_h$  is the phase shift of the harmonic component  $h$

This equation is used to describe any periodic function, which by definition is made up of the contribution of sinusoidal functions of different frequencies. The component with  $h = 1$  is called the fundamental component (or dominant frequency). The magnitude and phase angle of each harmonic component is what determines the resultant waveform  $f(t)$ . Generally, the frequencies of interest for harmonic analysis include up to the 40<sup>th</sup> or so harmonics.

In order to determine the magnitude of the harmonics that make up a distorted waveform, (and so ensure that regulatory limits are met) a mathematical operation known as a Fourier Transform is used. The Fourier Transform is simply a mathematical operation that decomposes a signal into its constituent

frequencies, allowing their magnitudes to be determined. For example, the breakdown of a current waveform into its fundamental component and its four dominant harmonics (harmonics with the greatest magnitudes) is shown in Figure 4 below.

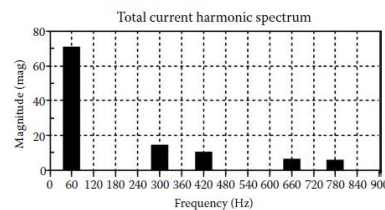
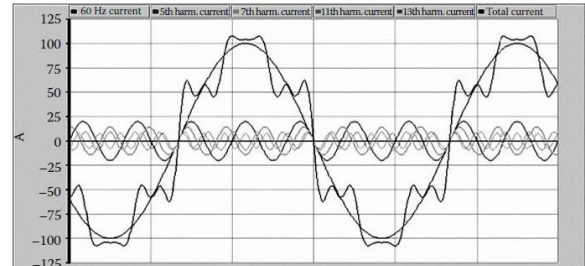
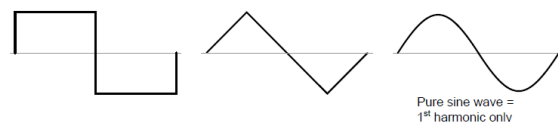

**Figure 4 Fundamental Harmonics**

Now that we understand a little more about harmonics, and how any periodic waveform is simply the summation of its fundamental component and its harmonics, we are better equipped to understand why some harmonics are considered to be worse than others.

#### Odd and Even Harmonics

When the non-sinusoidal waveform in question is symmetrical above and below its average centreline, the harmonic frequencies will be odd integer multiples of the fundamental source frequency only, with no even integer multiples. (Figure 5 below) The majority of loads produce current waveforms like this, and so even-numbered harmonics (2nd, 4th, 6th, 8th, 10th, 12th, etc.) are absent or only minimally present in most AC power systems.



**Figure 5 No Even Harmonics**

Examples of nonsymmetrical waveforms with even harmonics present are shown for reference in Figure 6 below.

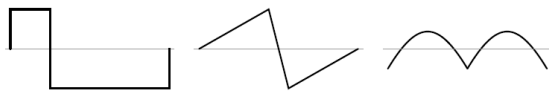

Figure 6 Even Harmonics Present

It is for this reason that the limits on even harmonics are more relaxed than those on odd harmonics. Even though half of the possible harmonic frequencies are eliminated by the typically symmetrical distortion of nonlinear loads, the odd harmonics can still cause problems.

### Three Phase Power and Triplen Harmonics

Triplen harmonics (defined as odd multiples of the third harmonic) are of a particular concern in three-phase power systems. To explain why, we look at the harmonic currents flowing in a three-phase, four-wire network.

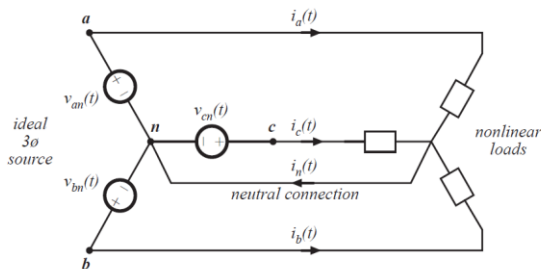

Figure 7 Three-Phase Four-Wire Network

The Fourier series of the line currents and voltages of the system shown above are as follows:

$$\begin{aligned}
 i_a(t) &= I_{a0} + \sum_{h=1}^{\infty} I_{ah} \cos(h\omega t - \theta_{ah}) \\
 v_{an}(t) &= V_m \cos(\omega t) \\
 i_b(t) &= I_{b0} + \sum_{h=1}^{\infty} I_{bh} \cos(h(\omega t - 120^\circ) - \theta_{bh}) \\
 v_{bn}(t) &= V_m \cos(\omega t - 120^\circ) \\
 i_c(t) &= I_{c0} + \sum_{h=1}^{\infty} I_{ch} \cos(h(\omega t + 120^\circ) - \theta_{ch}) \\
 v_{cn}(t) &= V_m \cos(\omega t + 120^\circ)
 \end{aligned}$$

Kirchoff's current law states that at any node (junction) in an electrical circuit, the sum of currents flowing into that node is equal to the sum of currents flowing out of that node. This means that the neutral current is equal to:

$$\begin{aligned}
 i_n(t) &= I_{a0} + I_{b0} + I_{c0} + \\
 &\sum_{h=1}^{\infty} \left[ I_{ah} \cos(h\omega t - \theta_{ah}) + I_{bh} \cos(h(\omega t - 120^\circ) - \theta_{bh}) + \right. \\
 &\left. I_{ch} \cos(h(\omega t + 120^\circ) - \theta_{ch}) \right]
 \end{aligned}$$

If the load is unbalanced, the neutral connection will simply contain currents which have a spectrum similar to the line currents.

However, in the case of a balanced load,  $I_{ah} = I_{bh} = I_{ch} = I_h$  and  $\theta_{ah} = \theta_{bh} = \theta_{ch} = \theta_h$ ; i.e., the harmonics of the three phases all have equal amplitudes and phase shifts. The neutral current is calculated as:

$$\begin{aligned}
 i_n(t) &= 3I_0 + \\
 &I_1(\cos(\omega t - \theta_1) + \cos((\omega t - \theta_1) - 120^\circ) + \cos((\omega t - \theta_1) + 120^\circ)) + \\
 &I_2(\cos(2\omega t - \theta_2) + \cos((2\omega t - \theta_2) + 120^\circ) + \cos((2\omega t - \theta_2) - 120^\circ)) + \\
 &I_3(\cos(3\omega t - \theta_3) + \cos((3\omega t - \theta_3) - 0^\circ) + \cos((3\omega t - \theta_3) + 0^\circ)) + \\
 &I_4(\cos(4\omega t - \theta_4) + \cos((4\omega t - \theta_4) - 120^\circ) + \cos((4\omega t - \theta_4) + 120^\circ)) + \\
 &\dots
 \end{aligned}$$

Using a certain amount of somewhat tedious mathematics, it can be shown that in the above expression, every harmonic bar the triplen harmonics (harmonics that are a multiple of three) cancel out to zero. Conversely, the triplen harmonics actually add, and so cause current to flow in the neutral connector. This is portrayed visually in Figure 8, where it is easy to see how the third harmonic has an additive effect.

This current flow in the neutral conductor can cause over heating and possibly cause fires if the conductor is not sized correctly, as well as causing havoc with transformers. The increased use of appliances which propagate harmonics can cause problems in older builds, where the conductor has been undersized. **This is why there are stringent limits on triplen harmonics, particularly higher order triplen harmonics.**

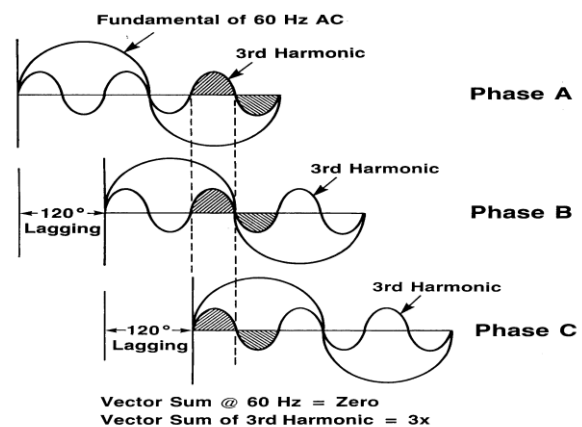

Figure 8 Addition of Triplen Harmonics

Negative Sequence Harmonics

In the last section, we saw how the 3rd harmonic and all of its integer multiples (collectively called triplen harmonics) generated by 120° phase-shifted fundamental waveforms are actually in phase with each other. In a 50 Hz three-phase power system, where phases A, B, and C are 120° apart, the third-harmonic multiples of those frequencies (180 Hz) fall perfectly into phase with each other.

Fundamental Phase Sequence = A-B-C			
Fundamental	A 0°	B 120°	C 240°
3 <sup>rd</sup> Harmonic	A 3 x 0° (0°)	B 3 x 120° (360° = 0°)	C 3 x 240° (720° = 0°)

**Table 2 Phase Shifts**

If we extend the mathematical table to include higher odd-numbered harmonics, we will notice an interesting pattern develop with regard to the rotation or sequence of the harmonic frequencies.

Fundamental	A 0°	B 120°	C 240°	A-B-C
3 <sup>rd</sup> Harmonic	A 3 x 0° (0°)	B 3 x 120° (360° = 0°)	C 3 x 240° (720° = 0°)	No Rotation
5 <sup>th</sup> Harmonic	A 5 x 0° (0°)	B 5 x 120° (600° = -120°)	C 5 x 240° (1200° = -240°)	C-B-A
7 <sup>th</sup> Harmonic	A 7 x 0° (0°)	B 7 x 120° (840° = 120°)	C 7 x 240° (1680° = 0°)	A-B-C
9 <sup>th</sup> Harmonic	A 9 x 0° (0°)	B 9 x 120° (1080° = 0°)	C 3 x 240° (2160° = 0°)	No Rotation

**Table 3 Harmonic Frequency Sequence**

Harmonics such as the 7th, which “rotate” with the same sequence as the fundamental, are called positive sequence harmonics. Harmonics such as the 5th, which “rotate” in the opposite sequence as the fundamental, are called negative sequence harmonics. Triplen harmonics (3rd and 9th shown in this table) which don’t “rotate” at all because they’re in phase with each other, are called zero sequence.

This pattern of positive-zero-negative-positive continues indefinitely for all odd-numbered harmonics, lending itself to expression in a table like this:

Rotation Sequence	Harmonic				
+	1 <sup>st</sup>	7 <sup>th</sup>	13 <sup>th</sup>	19 <sup>th</sup>	Rotates With Fundamental
0	3 <sup>rd</sup>	9 <sup>th</sup>	15 <sup>th</sup>	21 <sup>st</sup>	Does Not Rotate

-	5 <sup>th</sup>	11 <sup>th</sup>	17 <sup>th</sup>	23 <sup>rd</sup>	Rotates Against Fundamental

**Table 4 Harmonic Frequency Rotation**

Sequence especially matters when we’re dealing with AC motors, since the mechanical rotation of the rotor depends on the torque produced by the sequential “rotation” of the applied 3-phase power. Positive-sequence frequencies work to push the rotor in the proper direction, whereas negative-sequence frequencies actually work against the direction of the rotor’s rotation. Zero-sequence frequencies neither contribute to nor detract from the rotor’s torque. An excess of negative-sequence harmonics (5th, 11th, 17th, and/or 23rd) in the power supplied to a three-phase AC motor will result in a degradation of performance and possible overheating.

Since the higher-order harmonics tend to be attenuated more by system inductances and magnetic core losses, and generally originate with less amplitude anyway, the primary harmonic of concern is the 5th, which is 300 Hz in 60 Hz power systems and 250 Hz in 50 Hz power systems.

In summary, harmonics can cause the following consequences:

- Introduce neutral currents above 100% of the phase current, resulting in overheating and failure of the neutral phase. Case studies in commercial buildings have shown neutral currents of between 150% and 210% of the phase currents in the presence of high 3rd harmonic currents.
- Transformers can overheat resulting in reduced life and reduced rating (losses increase with the square of the harmonic number).
- Nuisance tripping of residual current circuit breakers.
- Over stressing of power factor correction capacitors.

Problems caused by harmonic voltages include:

- Increased losses in motors resulting in reduced power output and increased heating (reducing life expectancy)

Problems caused by harmonic frequencies

- Devices that use power-line carrier signals, such as synchronised clocks, control modules for building management systems and ripple control relays for management of hot water load may experience problems if harmonics exist at frequencies close to the carrier signal. *These harmonics cannot be*

*filtered out as the filtering will also filter out the power-line carrier signals.*

In order to avoid these consequences appliances are grouped due to a number of characteristics, and regulations placed on the level of their harmonics, with triplen and negative sequence harmonics being of a particular concern.

### **References**

- [1] “Harmonics and Power Systems”, Francisco C. De La Rosa
- [2] “Harmonics Explained”, Home Energy Metering.com, <http://www.home-energy-metering.com/harmonics.html>
- [3] “IEC 61000-3-2 Harmonics Standards Overview”, Muhamad Nazarudin Zainal Abidin, [http://www.teseq.com/com/en/service\\_support/technical\\_information/05\\_AN\\_IEC61000-3-25.p](http://www.teseq.com/com/en/service_support/technical_information/05_AN_IEC61000-3-25.p)
- [4] “Harmonic Current Emissions”, European Power Supply Manufacturers Association, [http://www.epsma.org/pdf/PFC%20Guide\\_November%202002.pdf](http://www.epsma.org/pdf/PFC%20Guide_November%202002.pdf)
- [5] “Fourier Transform”, Wikipedia, [http://en.wikipedia.org/wiki/Fourier\\_transform](http://en.wikipedia.org/wiki/Fourier_transform)
- [6] “Lessons In Electric Circuits”, Tony R. Kuphaldt
- [7] “Fundamentals of Power Electronics”, R. W. Erickson
- [8] “Harmonics – Understanding the Facts”, Richard P. Bingham
- [9] “Understanding Power Quality”, Dr. Bruce Girdwood
- [10] “Harmonic Currents”, Robert F. Martin, <http://www.ce-mag.com/99ARG/Martin103.html>

*Excelsys Technologies Ltd. is a modern world-class power supplies design company providing quality products to OEM equipment manufacturers around the world. This is achieved by combining the latest technology, management methods and total customer service philosophy with a 20 year tradition of reliable and innovative switch mode power supply design, manufacture and sales. If there are any further points you wish to discuss from this paper please contact [support@excelsys.com](mailto:support@excelsys.com). Further information on our products can also be found at [www.excelsys.com](http://www.excelsys.com)*

**Addendum**

Harmonic Order (n)	Maximum Permissible Harmonic Content (A)
Odd Harmonics	
3	2.3
5	1.4
7	0.77
9	0.40
11	0.33
13	0.21
$15 \leq n \leq 39$	$0.15 \times 8/n$
Even Harmonics	
2	1.08
4	0.43
6	0.30
$8 \leq n \leq 40$	$0.23 \times 8/n$

**Table 5 Limits for Class A Equipment**

Harmonic Content (n)	Maximum Permissible Harmonic Current Expressed as a Percentage of the Input Current at the Fundamental Frequency (%)
2	2
3	$30-\lambda^*$
5	10
7	7
9	5
$11 \leq n \leq 39$ (odd harmonics only)	3
* $\lambda$ is the circuit power factor	

**Table 6 Limits for Class C Equipment**

Harmonic Order (n)	Maximum Permissible Harmonic Current Per Watt (mA/W)	Maximum Permissible Harmonic Current (A)
3	3.4	2.30
5	1.9	1.14
7	1.0	0.77
9	0.5	0.40
11	0.35	0.33
$13 \leq n \leq 39$ (odd harmonics only)	$3.85/n$	See table 1

**Table 7 Limits for Class D Equipment**

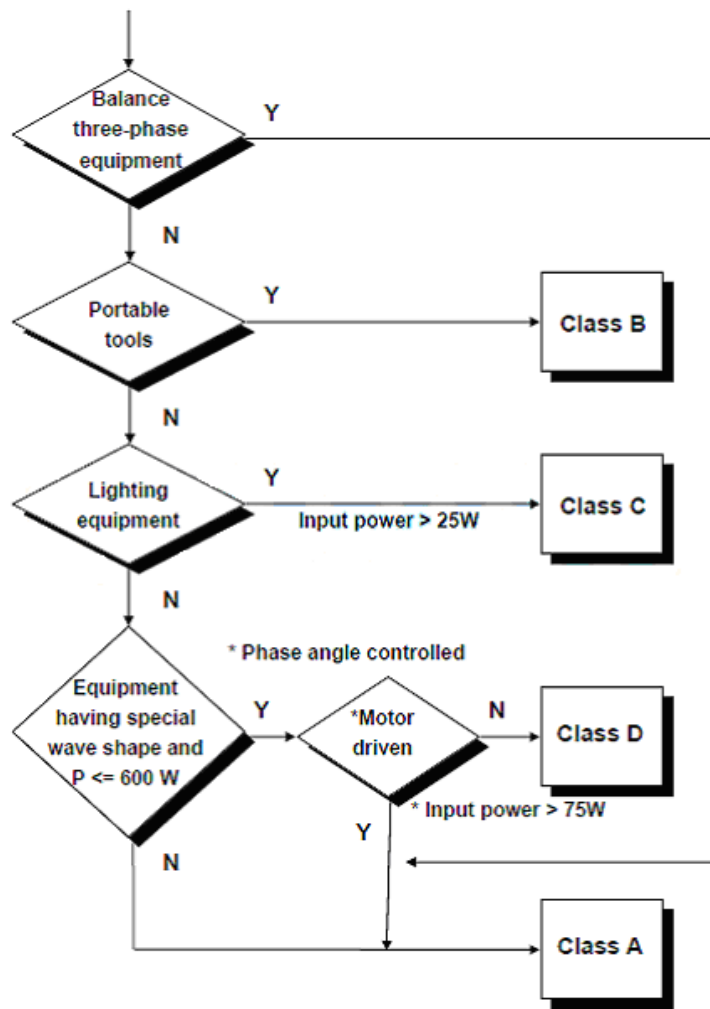

Figure 9 Class Flowchart