



400W/600W Configurable Switch Mode Power Supply

4 slot package size

FEATURES

- 1 to 8 isolated outputs with full user configurability
- 1.45V to 28V standard output voltages
- Isolated Bias Supply Voltage 5V @ 50mA
- Class B Conducted Emissions
- 400 and 600 Watts of output power
- Series and parallel capability
- Zero load operation
- EN61000-3-2 compliant
- Universal input
- Fully floating outputs
- Individual control signals on each module
- Modular construction
- Industry standard footprint
- 3 Year warranty

APPLICATIONS INCLUDE

- Industrial equipment
- Test and measurement
- Telecommunications
- Peripherals
- Audio/broadcast
- Automation
- Linear and rotary motion

3gen provides an instant, no compromise power solution for any power requirements where a unique set of voltage and current requirements is needed. Excelsys has coupled a 2 transistor forward converter front end with planar magnetic main transformer technology and modular magnetic amplifier output stages to provide a fast turn-around, production line built power solution that can be matched to meet your exact requirements for Volts and Amps. Configured units may be shipped within 48 hours to your exact set point requirements complete with CE and UL approval and fully compliant to EN61000-3-2.

Designed as a cost effective solution for single piece or volume production runs, the 3G4B and 3G4C series provide up to 600Watts of output power in a 270 x 127 x 65mm rugged extruded aluminium package. Power connections are made using quality screw terminal connections and primary and secondary controls enable power channels to be individually margined, enabled, paralleled or stacked to provide literally millions of power solutions to match your needs. Design resources available from the Excelsys web site www.excelsys.com include safety certification, CB reports, CAD profile drawings, handbooks and configuration software tools.

SINGLE OUTPUT MODULES		NOMINAL	RANGE	I _{max}
Module 1	1 Slot	5V	(3 to 5.6V)	30A
Module 2	1 Slot	12V	(5 to 13V)	20A
Module 3	1 Slot	18V	(8 to 20V)	15A
Module 4	1 Slot	24V	(12 to 28V)	12A
Module 70	2 Slots	5V	(1.45 to 5.6V)	80A
DUAL OUTPUT MODULE		NOMINAL	RANGE	I _{max}
Module 5	1 Slot	24V	(10 to 28V)	3A
		24V	(10 to 28V)	3A
Module 6	1 Slot	5V	(3 to 5.6V)	10A
		24V	(10 to 28V)	3A

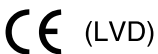

PRINCIPLE OF OPERATION

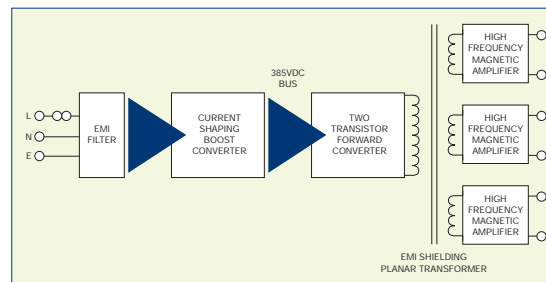

SPECIFICATION All specifications are typical at nominal input, full load at 25°C unless otherwise stated

OUTPUT SPECIFICATIONS

Maximum power (Note 1)	Input module B Input module C	400W 600W
Output adjustment (Note 2)	Multi-turn potentiometer	
Line regulation	±0.1%	
Load regulation	50% load change	±0.2%
Cross regulation	±0.2% typ.	
Transient response (Note 3)	<10%, <0.5ms	
Temperature coefficient	±0.02%/°C	
Ripple and noise (Note 4)	1.0% or 100mV pk-pk	
Overvoltage protection	Standard on all outputs	
Overcurrent protection (Note 5)	Individual current limit	
Thermal protection	Standard	
Mains failure signal	Option 03, 05, 06 or 07	5ms warning
Output isolation (Note 6)	Each single and dual output fully floating	
Margin	See AN105 for individual module margin capabilities	
Minimum load (Note 7)	Zero	
Turn-on delay	500ms	
Remote sense	Single outputs only	0.5V drop

INPUT SPECIFICATIONS

Input voltage range	Universal input	88 to 264VAC 125 to 370VDC
Input frequency range (Note 8)	47Hz to 63Hz	
Inrush current	230VAC @ 25°C	50A max.
Harmonic distortion (Power factor)	EN61000-3-2	

NOTES

- For higher power applications please see 6 slot datasheet.
- Outputs are user adjustable or factory set to your requested voltage.
- 25% to 75% load change.
- Whichever is greater. 20MHz bandwidth. (See AN105 for specification below 0°C).
- Straight line on all outputs. On Module 70 current limit adjustable from 50% to 110%. Optional foldback on Module 70. Contact factory for details and AN105.
- 100V isolation between each output and 500V to chassis.
- All outputs except Module 70, which has 5.0% minimum load for full specification.
- Contact factory for 400Hz operation.
- For nominal output voltages and full load.
- The specifications contained in this data sheet are believed to be correct at time of publication. Specifications are subject to change without notice.
- This product is not intended for use as a stand alone unit and must be installed by authorised personnel in order to maintain approvals.

EMC CHARACTERISTICS

Emissions:		
Conducted	EN55022, FCC	Level B
Immunity:		
Electrostatic discharge	EN61000-4-2	Level 4
Radiated RFI	EN61000-4-3	Level 3
Fast transients - burst	EN61000-4-4	Level 3
Input line surges	EN61000-4-5	Class 3
Conducted RFI	EN61000-4-6	Level 3
Voltage dips	EN61000-4-11	Compliant

GENERAL SPECIFICATIONS

Hold-up time (Note 9)	20ms typ after loss of AC power	
Efficiency	82% typ.	
Isolation voltage	Input/output Input/chassis	3000VAC 1500VAC
Switching frequency	200kHz	
Approvals and standards (Note 11)	IEC60950, UL1950 CSA22.2 No. 950	
Leakage current	1.25mA, 250VAC, 60Hz	
Weight	2.5kg	
Size	LxWxH	270 x 127 x 65 mm
MTBF	See AN105	400,000 hours

ENVIRONMENTAL SPECIFICATION

Operating temperature (See derating curve)	See AN105	-20°C to +50°C Derate 2.5% per °C up to +70°C
Storage temperature	-40°C to +85°C	
Relative humidity	Non-condensing	5% to 95% RH
Shock	3000 bumps, 10G (16ms) half sine	
Vibration	10-200Hz, 1.5G	

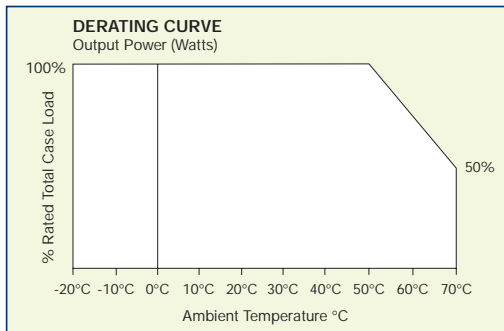

TYPICAL EMISSIONS TO EN55022 LEVEL B

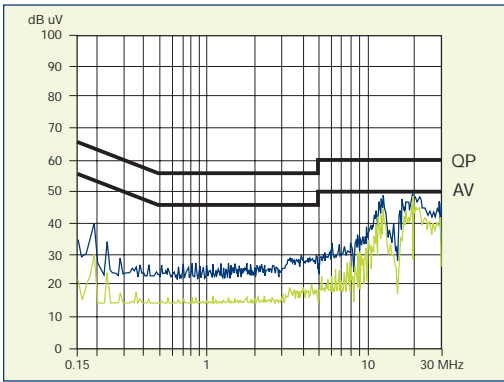

MECHANICAL SPECIFICATIONS

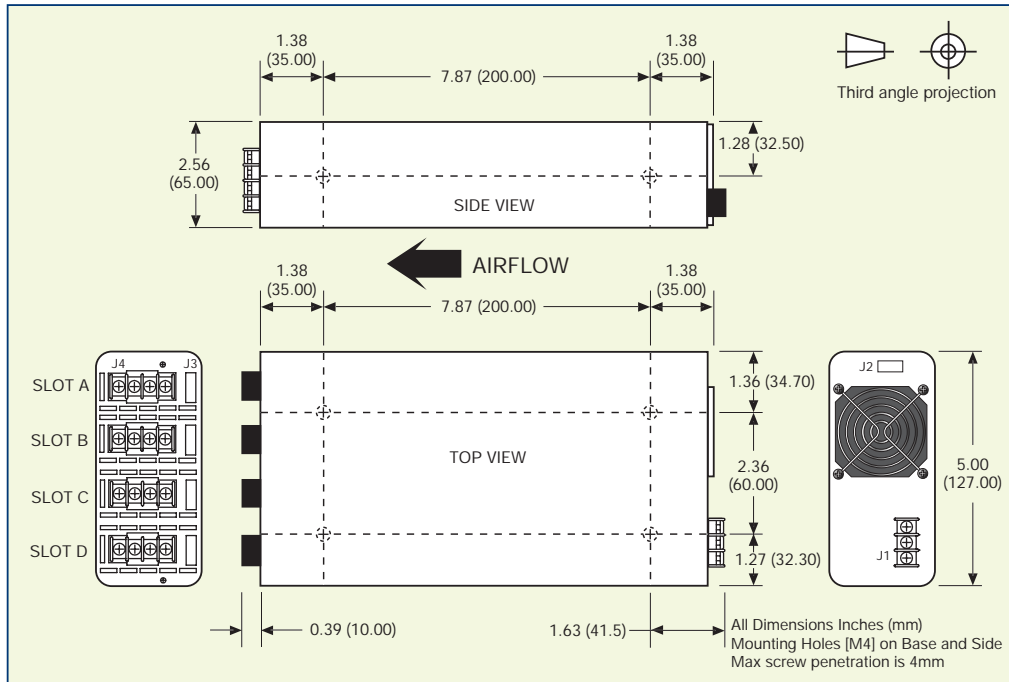

- Connectors:**
- J1** Line Input Connector
 - J2** Options
See AN105 for Pin-out
 - J3** Output Signals
See AN105 for Pin-out
 - J4** Output Connector

- Accessories:**
- 61069 Parallel Link
 - 61070 Series Link
 - 362D010 "U" Link
 - OPCONN4 Mating Connector for options + Module 1-6 signals
 - OPCONN6 Mating Connector for Module 70 signals

3gen 4 SLOT STANDARD OPTIONS

- 03** Mains Power Fail + Logic Enable
- 05** Mains Power Fail + Logic Inhibit
- 06** Mains Power Fail + Logic Enable + Bias Supply Voltage
- 07** Mains Power Fail + Logic Inhibit + Bias Supply Voltage

Options: Mutually exclusive

OUTPUT SIGNALS

Output control signals are available on all output modules.

- | | |
|--|---|
| Modules 1 to 6 | Module 70 Additional Features (See AN105) |
| <ul style="list-style-type: none"> • Power good signal • Output inhibit signal • Remote adjust (margin) | <ul style="list-style-type: none"> • Adjustable Current Limit • Foldback or Straight Line Current limiting • Bias Voltage • Selectable Output Inhibit or Enable |

(Dual output modules: output signals available on first [top] output only).

HOW TO ORDER

Note: Calculate power requirements by summing output powers calculated at NOMINAL output voltages.

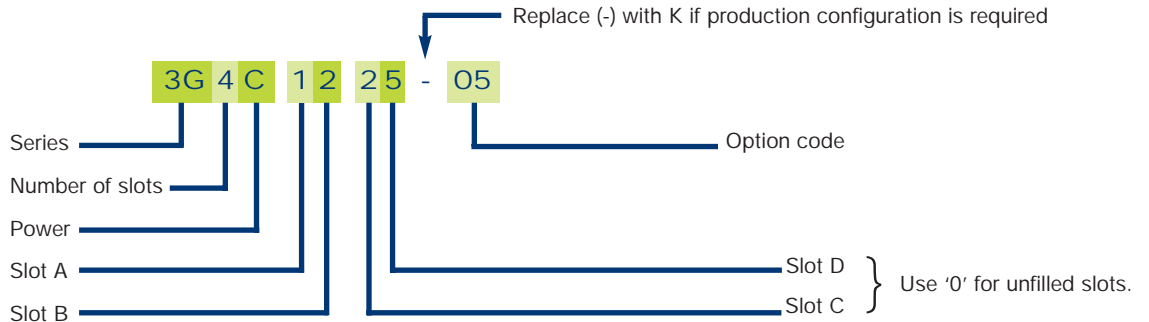

Specification of power supply detailed above:

- 4 slot series
- Maximum output power: 600W
- 5V @ 30A; 12V @ 20A; 12V @ 20A; 24V @ 3A; 24V @ 3A
- Mains Power Fail Signal + Logic Inhibit

Production configuration:

Units are shipped with nominal output voltages unless production configuration is specified. Excelsys can configure to your exact requirements, through use of appropriate parallel and series busbars and through voltage adjustment to specific set points. Please refer to configuration sheet for details (MD-3GCONFIG-05/00) and for part number assignment to our website at www.excelsys.com.

3gen FLEXIBILITY

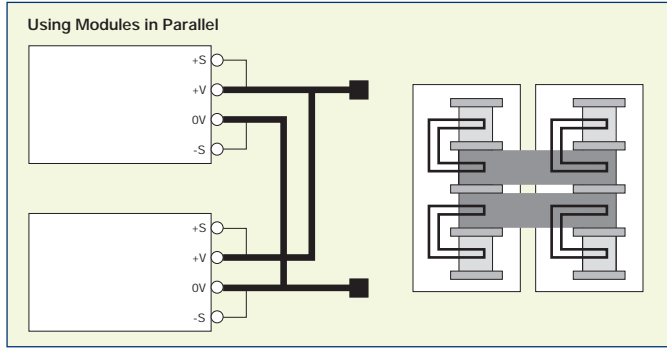

Notes:
 Maximum current = $(I_1 + I_2) \times .9$
 Use two parallel links (P/N 61069)

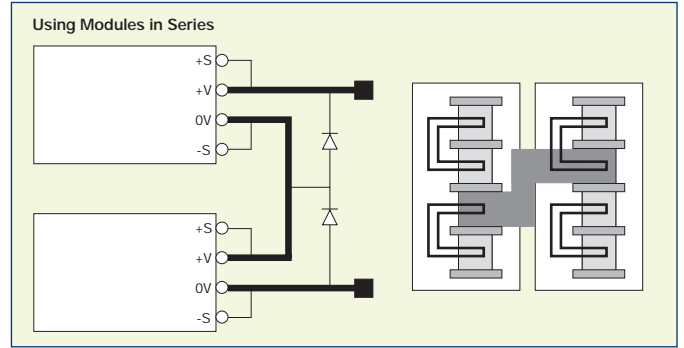

Notes:
 Maximum voltage to chassis is 500V
 Use series link (P/N 61070)
 Reverse bias diodes may be required for certain applications, eg. large capacitive loads

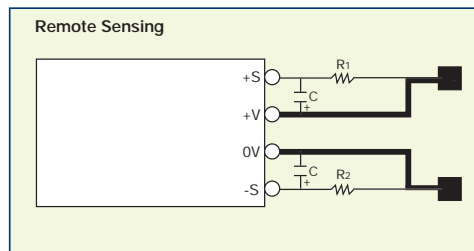
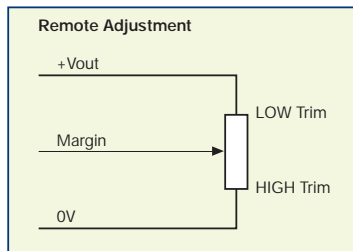

Notes:
 Where the sensing point is remote from the output of the power supply, to avoid spurious noise pick-up it may be necessary to:

- 1 Use twisted pair sense wires.
- 2 Use R C as shown ($R_1 = 100\Omega$) ($R_2 = 10\Omega$) ($C = 22\mu F$).

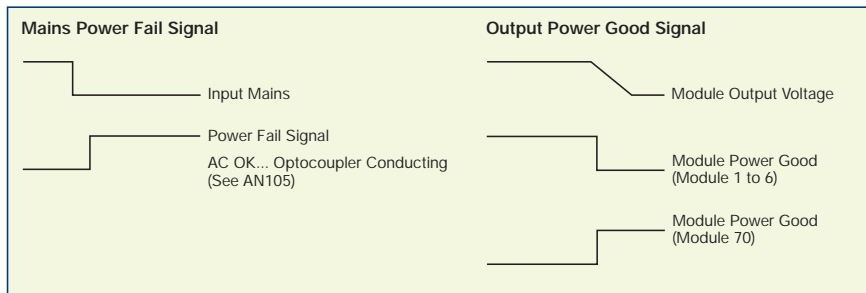

Notes:
 See Application Note AN105, or visit excelsys website www.excelsys.com for full details.

