



3gen 3med Power Supply Series

APPLICATIONS and ENGINEERING HANDBOOK

AN105

Document no.	Title	Title (Short form)
40001	3Gen and 3Med Series Applications Handbook AN 105	

Revision	Prepared	date	Released	date	Excelsys Technologies Ltd. Swords Business Park, Swords, Co. Dublin, Ireland. (T) +353 1 890 0933 (F) +353 1 890 1358
First	Seamus Devitt	29/05/00	Paul Fenton	27/06/00	
Current 10	Dermot Flynn	13/1/04	NvdW	13/1/04	

This document and its contents are the copyright property of Excelsys Technologies Ltd. and may not be copied in whole or in part without written permission.

CONTENTS

- 0 Scope**
- 1 Installation Guidelines**
- 2 Input Specifications**
- 3 Output Specifications**
- 4 Signals**
- 5 Advanced Features**
- 6 Power Supply Reliability**
- 7 Safety Standards**
- 8 Safety, Regulatory & EMI Specifications**
- 9 Connector Details**
- 10 Mechanical Drawings**
- 11 Configuration Rules**

©Copyright: This manual is the copyright of Excelsys Technologies Ltd. and may not be reproduced or copied without written permission.

Document no.	Title	Title (Short form)
40001	3Gen and 3Med Series Applications Handbook AN 105	

Revision	Prepared	date	Released	date	Excelsys Technologies Ltd. Swords Business Park, Swords, Co. Dublin, Ireland. (T) +353 1 890 0933 (F) +353 1 890 1358
First	Seamus Devitt	29/05/00	Paul Fenton	27/06/00	
Current 10	Dermot Flynn	13/1/04	NvdW	13/1/04	Page 2 of 26
This document and its contents are the copyright property of Excelsys Technologies Ltd. and may not be copied in whole or in part without written permission.					

0. SCOPE

This manual provides general installation, use and application guidelines for the Excelsys range of 3gen and 3med power supplies. It should be read in conjunction with product datasheets. Latest revisions of datasheets and this manual may be downloaded in PDF format from www.excelsys.com.

1. GENERAL INSTALLATION GUIDELINES

- The 3gen and 3med Series are designed for use within other equipment or enclosures which restrict access to authorised competent personnel only.
- Slots in the product case are designed for ventilation and must not be obstructed when the product is installed and / or operated.
- Make sure the unit is supplied only by a power source of the type indicated on its label.
- An appropriate disconnect device must be provided as part of the building installation.
- When securing the product, do not use screws which infringe the maximum penetration depth specified on the mechanical drawings in the 3gen and 3med datasheets (i.e. 4mm)
- The unit covers are designed only to protect skilled personnel from hazards. They must not be used as part of the external covers of any equipment where they may be accessible to operators, since, under full load conditions, part or parts of the unit may reach temperatures in excess of those considered safe for operator access.
- AFTER DISCONNECTING THE AC SOURCE, ALLOW 4 MINUTES BEFORE REMOVING COVERS TO ALLOW CAPACITORS WITHIN THE UNIT TO DISCHARGE.

Earth Terminal Marking **IMPORTANT**

If in the end use equipment the incoming mains cable earth wire connects directly to the "GND" connection on the 3gen/3med unit without being interrupted or junctioned on its way to that connection, then this connection forms the main protective earth of the system, and to comply with IEC950, EN60950, UL1950, IEC601-1, EN60601-1 and UL2601-1 requirements then this must be marked with the symbol defined in the IEC417 No. 5019a. The customer should therefore affix an adhesive label which will pass the 15 Second rub test (IEC950 section 1.7.15) showing the symbol below adjacent to the earth connection. This symbol must only be used at the first interruption / connection of the incoming earth wire.



Health And Safety At Work Act (UK only)

In order to protect service personnel and users of these power supplies and to comply with section 6 of the Health And Safety Acts, a clearly visible label should be fitted warning that surfaces of these units may be hot and must not be touched when the units are in operation.

Mounting Requirements And Cooling

The mechanical outline drawings in the data sheet give the necessary information for the customer fixings. **WARNING: DO NOT EXCEED THE MAXIMUM SCREW PENETRATION DEPTH OF 4 mm.** These units contain an integral fan and can be mounted in any orientation provided that the air intake and air outlet slots are not impeded. Customer fixings are provided on one side of the unit and the base (see mechanical drawings). When mounting any unit in other equipment, particular regard must be paid to provide ventilation holes in any chassis on which or near which the unit is mounted.

Document no.	Title	Title (Short form)
40001	3Gen and 3Med Series Applications Handbook AN 105	

Revision	Prepared	date	Released	date	Excelsys Technologies Ltd. Swords Business Park, Swords, Co. Dublin, Ireland. (T) +353 1 890 0933 (F) +353 1 890 1358
First	Seamus Devitt	29/05/00	Paul Fenton	27/06/00	
Current 10	Dermot Flynn	13/1/04	NvdW	13/1/04	
This document and its contents are the copyright property of Excelsys Technologies Ltd. and may not be copied in whole or in part without written permission.					Page 3 of 26

2. INPUT SPECIFICATIONS

Input Voltage Rating	110/230 Volts AC Universal	
Input Voltage Range	88 to 264 Volts AC	
Input Frequency (1)	47 to 63 Hz	
Input Surge (2)	< 50 A	
Thermal Protection	Standard	
Power Factor(3)	Typ. 0.98	
Mains Failure Signal (4)	5mS warning	
Earth Leakage Current (5)	3G4B, 3G4C	1.25mA
	3G6C, 3G6D	1.75mA
Earth Leakage Current (6)	3M4B, 3M4C	300µA
	3M6C, 3M6D	300µA
	3M4E	150µA

- (1) Consult factory for 400Hz operation
 (2) At 230VAC, lasts less than 20m S
 (3) Conforms to EN61000-3-2
 (4) See Section 4, SIGNALS
 (5) As per EN60950 at 250VAC, 60Hz
 (6) As per EN60601-1 at 250VAC, 60Hz

Input Connections

The safety approved input terminal block is accessible on the input end plate of the power supply. Connections should be made using appropriately coloured mains wires, which have no loose strands.

Input Fusing

Model	Fuse Rating	Fuse Voltage	Type	Size
3G4B	8A	250V	Fast Acting	6.3 x 30
3G4C	10A	250V	Fast Acting	6.3 x 30
3G6C	10A	250V	Fast Acting	6.3 x 30
3G6D	15A	250V	Fast Acting	6.3 x 30
3M4B	8A	250V	Fast Acting	6.3 x 30
3M4C	10A	250V	Fast Acting	6.3 x 30
3M6C	10A	250V	Fast Acting	6.3 x 30
3M6D	15A	250V	Fast Acting	6.3 x 30

3M4E is a dual fused version.

3M4E	2 Fuses	10A	250V	Fast Acting	6.3 x 30
------	---------	-----	------	-------------	----------

EMC and RFI Emissions

The 3gen and 3med Series are designed to operate such that mains conducted RFI is compliant with EN55022 and EN55011 respectively. See below for levels achieved on each model

Document no.	Title	Title (Short form)
40001	3Gen and 3Med Series Applications Handbook AN 105	

Revision	Prepared	date	Released	date	Excelsys Technologies Ltd. Swords Business Park, Swords, Co. Dublin, Ireland. (T) +353 1 890 0933 (F) +353 1 890 1358
First	Seamus Devitt	29/05/00	Paul Fenton	27/06/00	
Current	10	Dermot Flynn	13/1/04	NvdW	13/1/04
This document and its contents are the copyright property of Excelsys Technologies Ltd. and may not be copied in whole or in part without written permission.					Page 4 of 26

3. OUTPUT SPECIFICATIONS

A variety of standard output modules are available, current models are listed in table 1 below. This range is being continuously added to by Excelsys Technologies Ltd., and the user may find the latest additions to this range on www.excelsys.com. The part numbering system clearly identifies which modules are factory installed into a particular power supply. This is also clearly indicated on the output label situated on top of the power supply.

Ratings (1) (1a)	400W, 600W, 1000W
Output Range	As per output table
Output Adjustment Manual	Multiturn potentiometer
Output Adjustment Electronic	See table 1
Line Regulation (2)	+/- 0.1%
Load Regulation (3)	+/- 0.2%
Hold-Up (4)	20mS typ. after loss of AC
Minimum Load	Zero
Ripple & Noise (5)	1% or 100 mV peak to peak
Temperature Coefficient	+/- 0.02% per Degree C
Over Current Protection (6)	Straight line current limit
Over Voltage Protection (7)	Standard on all outputs
Turn-on delay	typ. 500mS
Remote Sense (8)	Single Output Modules only
Cross Regulation	< 0.2%
Output Isolation (9)	Each output fully floating
Transient response (10)	< 10%, <0.5 mS

(1) See power selection table in data sheet

(1a) 3G6D and 3M6D, 1000W peak power for 10s, (800W average power) for Vin less than 180VAC

(2) For +/- 10% change from nominal line

(3) For 50% load change

(4) For nominal output voltages only

(5) Whichever is greater, 20MHz bandwidth. See notes below on Measurement of Ripple and Noise.

(6) See below for Over Current Protection set levels. On Module 70 current limit is adjustable as per table below. Optional fold-back current limit on Module 70

(7) See below for Over Voltage Protection set levels

(8) 0.5V drop max., subject to module voltage rating

(9) 100VDC between outputs and 500VDC output to chassis

(10) 25% to 75% load change

Measurement of Ripple & Noise

As with all switched mode power supplies, it is important to ensure that the correct method is used to verify ripple & noise. Care should be taken to ensure that a loop antenna is not formed by the tip and ground lead of the oscilloscope probe as this would lead to erroneous readings consisting mainly of pickup from remnant radiation in the vicinity of the output connectors. Excelsys recommends the use of a x1 probe with the ground sheath of the probe tip used for ground connection.

In some applications, further erroneous readings may result from CM currents. These can be reduced by looping a few turns of the scope lead through a suitable high permeability ferrite ring.

Document no.	Title	Title (Short form)
40001	3Gen and 3Med Series Applications Handbook AN 105	

Revision	Prepared	date	Released	date	Excelsys Technologies Ltd. Swords Business Park, Swords, Co. Dublin, Ireland. (T) +353 1 890 0933 (F) +353 1 890 1358
First	Seamus Devitt	29/05/00	Paul Fenton	27/06/00	
Current	10	Dermot Flynn	13/1/04	NvdW	13/1/04
This document and its contents are the copyright property of Excelsys Technologies Ltd. and may not be copied in whole or in part without written permission.					

As most loads powered by a power supply will have at least small values of differential capacitors located near the load, Excelsys also recommends the use of small value of capacitance (approx 1uF) positioned at the point of measurement.

Table 1. Output Module Specifications

Module	Output	Nom Voltage	Pot Set Range Range	Current I _{max}	OVP Regulation Voltage	Current Limit Onset	Short ⁽²⁾ Circuit Current	Control Trim Range
#	#	Volts	Volts	Amps	Volts	Amps	Amps	% from set-point
1	O/P1	5	3 – 5.6	30	6.5	33	36	+9/-20
2	O/P1	12	5 – 13	20	15	22	24	+9/-25
3	O/P1	18	8 – 20	15	23	16.5	18	+9/-40
4	O/P1	24	12 – 28	12	31	13	15	+9/-50
	O/P1	24	12 – 28	3	31	3.5	4	+9/-50
5	O/P2	24	10 – 28	3	31	3.5	4	-
	O/P1	5	3 – 5.6	10	6.5	11	12	+9/-20
6	O/P2	24	10 – 28	3	31	3.5	4	-
	O/P1	5	1.45 – 5.6	80	6.5	85 ⁽¹⁾	8.5	+9/-20

Note 1. Module 70 Current limit adjustable from 40A to 85A. See ADVANCED FEATURES.
 Note 2. Short Circuit Current Limit values apply to V_{out} > 0.5V

Over Current Protection Set Levels

Over current protection is implemented by means of straight-line current limit, which comes into effect at approximately 110% -115% of maximum rated current, see table 1

Over Voltage Protection Set Levels

Overvoltage protection is implemented on each 3gen/3med output by means of a complementary regulation loop, which comes into operation, in the unlikely event of a failure of the main regulation loop. The over voltage regulation voltage levels for each output are set out in table 1.

See ADVANCED FEATURES for details on programming OVP levels.

Output Voltage Adjustment and Remote Sense

All output modules have voltage adjustment. The adjustment potentiometer is accessible through the module front panel. To compensate for voltage drops in the output leads, use remote sensing. Remote sensing is available on all single output modules.

Remote sensing may be implemented by removing the local sense links connecting Positive Output to Positive Sense and Negative Output to the Negative Sense and then connecting the sensing terminals directly to the load (Modules 1,2,3,4 only. Module 70 sense terminals located on Signal connector J3. See section 9) The maximum line drop, which can be compensated for by remote sensing, is 0.5V, subject to not exceeding the maximum module voltage at the output terminals.

Document no.	Title	Title (Short form)
40001	3Gen and 3Med Series Applications Handbook AN 105	

Revision	Prepared	date	Released	date	Excelsys Technologies Ltd. Swords Business Park, Swords, Co. Dublin, Ireland. (T) +353 1 890 0933 (F) +353 1 890 1358
First	Seamus Devitt	29/05/00	Paul Fenton	27/06/00	
Current	10	Dermot Flynn	13/1/04	NvdW	13/1/04
Page 7 of 26					

This document and its contents are the copyright property of Excelsys Technologies Ltd. and may not be copied in whole or in part without written permission.

NOTE:

- Use separate twisted pairs for power and remote sense wiring.
- Route the sensing leads to prevent pick up, which may appear as ripple on the output.
- Never disconnect the output power rail with the sensing still connected to the load.
- If remote sense points are too distant, the PSU may oscillate. See ADVANCED FEATURES

Permitted Power Ratings for Reliable Operation

When specifying a 3gen/3med unit in an application it is necessary to ensure that output modules and input modules are operating within their power output capabilities.

3gen output modules are designed to provide maximum output power at the nominal output voltages. To calculate the maximum permissible output power that may be drawn from any output model, multiply the Nominal Output Voltage by I_{max}. These values may be found in the output module selection chart.

The power capability of 3gen input stage must always be calculated by summing the output module powers specified in the application. For modules operating at nominal output voltage or below calculate this using Nominal Output Voltage multiplied by Actual Current. For output modules set above nominal output voltage use the Set Point Voltage multiplied by the Actual Current. These, when summed, must not exceed the input module's power rating.

Input and output modules must be derated for temperature, linearly from 100% of rated power at 50 deg. C to 50% of rated power at 70 deg. C.

When using output modules in parallel use full current (not derated) capacity for all power calculations.

1000 watt Input modules "D" have a maximum power capability of 1000 watts at input voltages above 181 Volts. Below 180 Volts, the average power must be limited to 800 watts. 1000W peaks must be limited to 10seconds.

Note:

In the region between -20 degrees and 0 degrees, Ripple and Noise specifications are 175% of the nominal levels.

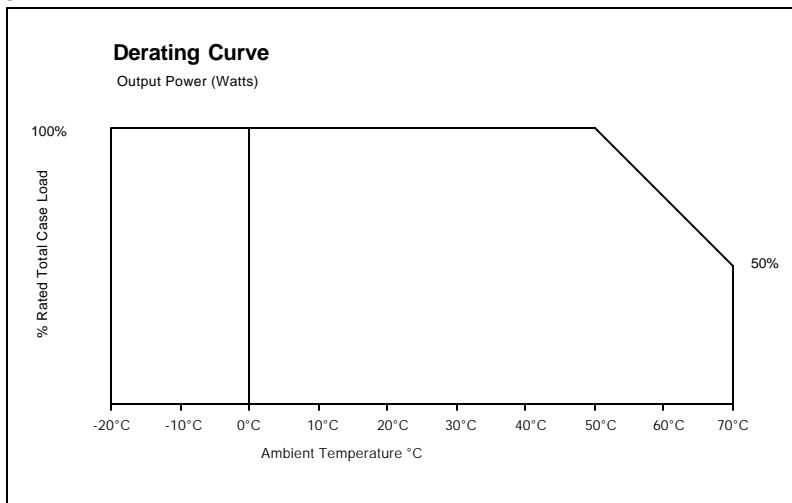

Document no.	Title	Title (Short form)
40001	3Gen and 3Med Series Applications Handbook AN 105	

Revision	Prepared	date	Released	date	Excelsys Technologies Ltd. Swords Business Park, Swords, Co. Dublin, Ireland. (T) +353 1 890 0933 (F) +353 1 890 1358
First	Seamus Devitt	29/05/00	Paul Fenton	27/06/00	
Current 10	Dermot Flynn	13/1/04	NvdW	13/1/04	

Page 8 of 26
This document and its contents are the copyright property of Excelsys Technologies Ltd. and may not be copied in whole or in part without written permission.

4. SIGNALS

INPUT SIGNALS (options 03,05,06,07 mutually exclusive) Connector J2

03 Mains Power Fail + Global Enable

05 Mains Power Fail + Global Inhibit

Mains Fail signal is implemented by an Opto-isolated signal with a maximum sink current of 4mA. During normal operation the transistor is ON. When the input voltage is lost, the opto – transistor is turned OFF at least 5mS before loss of output regulation (at nominal or below). The transistor also turns off at approximately 80 Volts AC.

Global Enable/Inhibit function is implemented by an Opto-isolated photo-diode requiring 5mA of external current to enable/inhibit ALL outputs. It is good practice to provide reverse voltage protection to the opto-coupler diode by means of an external inverse diode.

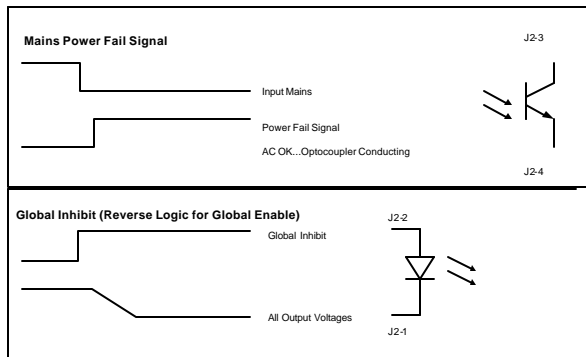

06 Mains Power Fail + Global Enable + Isolated Bias Supply voltage.

07 Mains Power Fail + Global Inhibit + Isolated Bias Supply voltage.

Mains Fail and Global Enable/Inhibit signals as above. An isolated bias supply voltage of 5V @ 50mA is provided. This allows the Enable/Inhibit function to be achieved by simple means of contact closure.

Document no.	Title	Title (Short form)
40001	3Gen and 3Med Series Applications Handbook AN 105	

Revision	Prepared	date	Released	date	Excelsys Technologies Ltd. Swords Business Park, Swords, Co. Dublin, Ireland. (T) +353 1 890 0933 (F) +353 1 890 1358
First	Seamus Devitt	29/05/00	Paul Fenton	27/06/00	
Current 10	Dermot Flynn	13/1/04	NvdW	13/1/04	
This document and its contents are the copyright property of Excelsys Technologies Ltd. and may not be copied in whole or in part without written permission.					Page 9 of 26

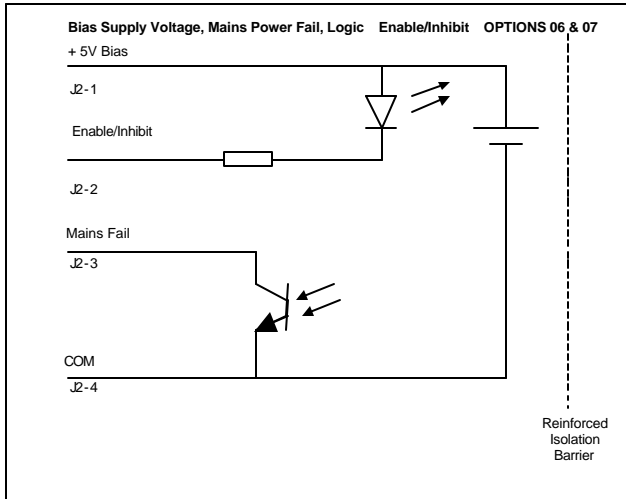

Document no.	Title	Title (Short form)
40001	3Gen and 3Med Series Applications Handbook AN 105	

Revision	Prepared	date	Released	date	Excelsys Technologies Ltd. Swords Business Park, Swords, Co. Dublin, Ireland. (T) +353 1 890 0933 (F) +353 1 890 1358
First	Seamus Devitt	29/05/00	Paul Fenton	27/06/00	
Current 10	Dermot Flynn	13/1/04	NvdW	13/1/04	

This document and its contents are the copyright property of Excelsys Technologies Ltd. and may not be copied in whole or in part without written permission.

J2 Connector Pin-out (Option 03, 05)

1. Enable/Inhibit Negative (Diode Cathode)
 2. Enable/Inhibit Positive (Diode Anode)
 3. Mains Fail Positive (Transistor Collector)
 4. Mains Fail Negative (Transistor Emitter)
- Mating Connector 50-37-5043 (Molex)
Pin 08-70-1040 (Molex)

J2 Connector Pin-out (Option 06, 07)

1. 5V @ 50mA SELV Output
 2. Global Enable/Inhibit Input
 3. Mains Fail Positive (Open Collector)
 4. COM
- Mating Connector 50-37-5043 (Molex)
Pin 08-70-1040 (Molex)

OUTPUT SIGNALS (standard on all outputs) Connector J3

Remote Inhibit (Modules 1,2,3,4,5,6)

Module voltage is pulled low (<2V at zero load) if the remote inhibit pin is raised to greater than 3 Volts. Minimum current required 2mA (Maximum voltage 10 Volts).

Remote Inhibit (Module 70)

Module may be inhibited by simple contact closure. Module voltage is pulled low (<0.2V @zero load) if the remote inhibit pin is connected to -Sense or -Vout. Note reverse logic (i.e. Remote Enable is possible by setting internal DIP switch. See ADVANCED FEATURES).

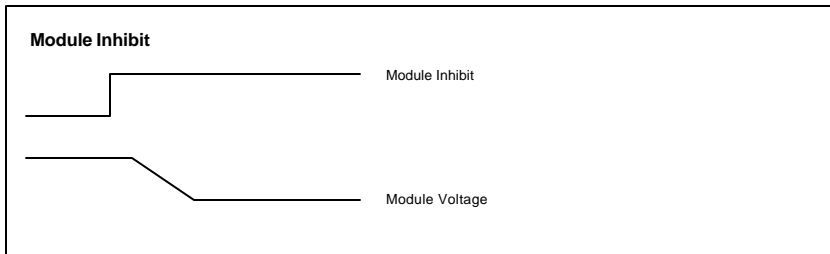

Module Power Good (Modules 1,2,3,4,5,6)

High signal indicates output within regulation. Low signal indicates output voltage is more than 10% below set voltage (Maximum Source Current 10mA, Maximum Sink Current 5mA).

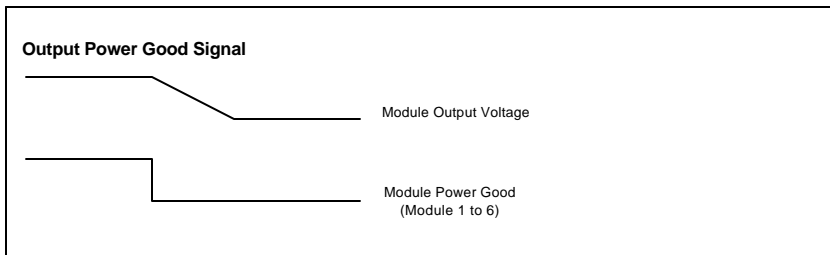

Module Power Good (Module 70)

Open collector signal is pulled low (10mA, 30V max) when output voltage is within regulation specification. Open collector signal pulled high indicates output voltage is more than 10% below set voltage.

Document no.	Title	Title (Short form)
40001	3Gen and 3Med Series Applications Handbook AN 105	

Revision	Prepared	date	Released	date	Excelsys Technologies Ltd. Swords Business Park, Swords, Co. Dublin, Ireland. (T) +353 1 890 0933 (F) +353 1 890 1358
First	Seamus Devitt	29/05/00	Paul Fenton	27/06/00	
Current 10	Dermot Flynn	13/1/04	NvdW	13/1/04	

This document and its contents are the copyright property of Excelsys Technologies Ltd. and may not be copied in whole or in part without written permission.

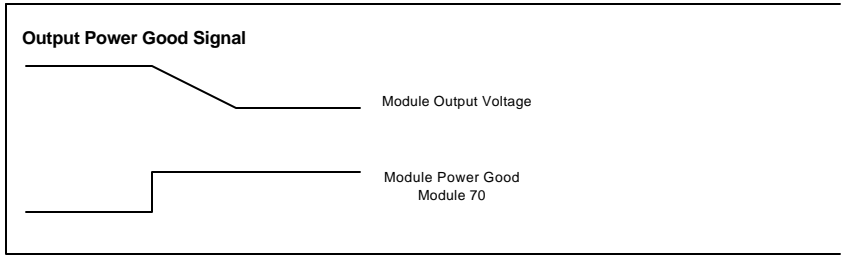

Margin Pin

Output voltage may be remotely adjusted by means of an external resistor or potentiometer network connected to the margin pin. Allows for both increase and decrease of output voltage. See table 1 for Control Trim range on each module. See ADVANCED FEATURES for remote potentiometer adjustment.

NOTE: These pins are referenced to the negative output rail. NEVER attempt to draw power from any of these pins.

Bias Voltage (Module 70 only)

Module 70 also provides a separate SELV bias supply voltage of 5V @ 25mA. This bias supply voltage is present irrespective of whether the module 70 is Enabled or Inhibited. It may be used to Enable/Inhibit the module 70 by means of simple contact closure.

J3 Connector Pin-out (Module 1,2,3,4,5,6)

1. Module Power Good
2. COM
3. Remote Inhibit
4. Margin

Mating Connector 50-37-5043 (Molex)
Pin 08-70-1040 (Molex)

J3 Connector Pin-out (Module 70)

1. Positive Sense
2. COM (Negative Sense)
3. +5V Bias (25mA max)
4. Margin
5. Remote Inhibit/Enable
6. Module Power Good

Mating Connector 50-37-5063(Molex)
Pin 08-70-1040(Molex)

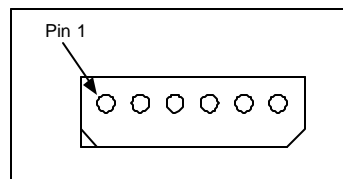
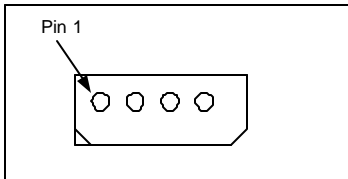

Document no.	Title	Title (Short form)
40001	3Gen and 3Med Series Applications Handbook AN 105	

Revision	Prepared	date	Released	date	Excelsys Technologies Ltd. Swords Business Park, Swords, Co. Dublin, Ireland. (T) +353 1 890 0933 (F) +353 1 890 1358
First	Seamus Devitt	29/05/00	Paul Fenton	27/06/00	
Current 10	Dermot Flynn	13/1/04	NvdW	13/1/04	
This document and its contents are the copyright property of Excelsys Technologies Ltd. and may not be copied in whole or in part without written permission.					Page 12 of 26

5. ADVANCED FEATURES

The 3gen and 3med series of products have been designed to allow maximum flexibility in meeting the unique requirements of individual users. The inherent flexibility resulting from modularity concepts is further enhanced by the ability to utilise more advanced features of this product range.

Although the products are very versatile, care should be taken when using advanced features to ensure that the proper procedures are followed. Several non-obvious precautions are necessary to achieve the quoted specifications and to avoid unintentional damage to the power supply. It is strongly recommended that the following paragraphs be studied carefully before attempting to use advanced features. **WARRANTY IS VOID IF DIP SWITCH SETTINGS ON MODULE 70 ARE CHANGED BY OTHER THAN AUTHORISED PERSONNEL.**

Series Connection of Modules

It is possible to connect modules in series to increase output voltage.

Outputs are rated SELV (Safety Extra Low Voltage), that is, that output voltages are guaranteed to less than 60 volts. Stacking output modules can exceed SELV, the user must take appropriate precautions. It is good practice to stack modules with similar output current limits, so that in the case of short circuit the outputs collapse together,

The exterior sense connections should connect to the load either locally or at point of use, and the interior connections using U connectors to the local sense. Special links for series connection modules (part number 61070) to reduce wiring complexity can be specified and fitted by the installer or added at the factory (see configuration ordering sheet MD-3GCONFIG-05/00)

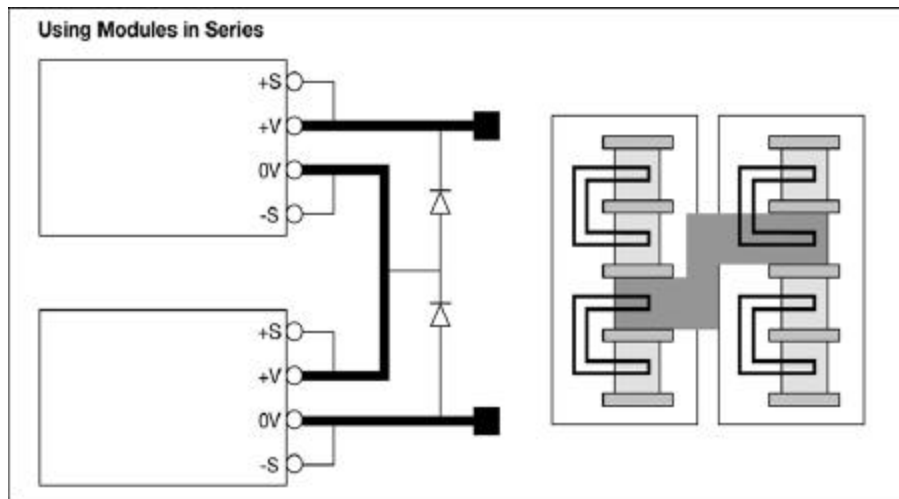

Simple Parallel Connection of Modules

Modules may be paralleled to increase output current. In this application the maximum continuous output current should not exceed 90% of the sum of the output currents. Only modules of the same type may be paralleled and the installer should follow the paralleling set-up procedure below

- Derate each module by 10%.
- Use local sensing links

Document no.	Title	Title (Short form)
40001	3Gen and 3Med Series Applications Handbook AN 105	

Revision	Prepared	date	Released	date	Excelsys Technologies Ltd. Swords Business Park, Swords, Co. Dublin, Ireland. (T) +353 1 890 0933 (F) +353 1 890 1358
First	Seamus Devitt	29/05/00	Paul Fenton	27/06/00	
Current	10	Dermot Flynn	13/1/04	NvdW	13/1/04
This document and its contents are the copyright property of Excelsys Technologies Ltd. and may not be copied in whole or in part without written permission.					

- Adjust the setting on each output module separately to the same value

Excelsys supply special parallel link connection bars (part number 61069) for parallel connection to reduce wiring complexity. These can be fitted at the factory (see configuration ordering sheet MD-3GCONFIG-05/00)

Simple Paralleling does not force current sharing, but is sufficient for most applications.

A Simple Schematic is shown below, showing the interconnection between 2 modules. The links shown can be created with "U" and "I" links rather than hard wiring

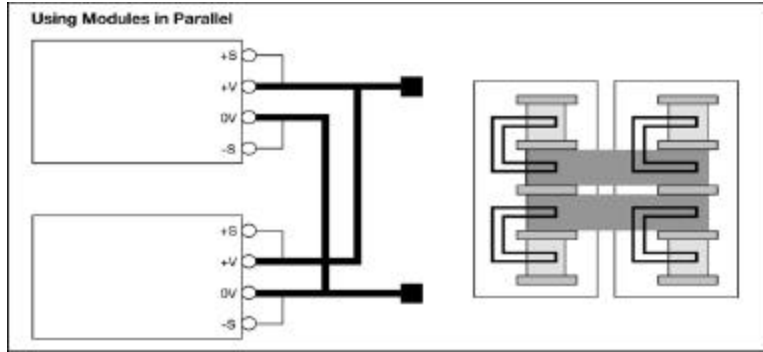

Forcing Current Sharing between Modules

This may be achieved by use of Excelsys proprietary *wireless* current sharing as follows:

- Only parallel modules of the same type
- Derate each module by 10%
- Use negative sensing **only** (either local or remote). Do NOT use positive sensing
- Adjust the setting on each output module separately, but to the same value
- For best performance, ensure symmetry in power cabling
- Take power from the +V terminal only
- Measure the voltage between the +S terminals on each output and trim the adjustment potentiometer on one module to null (=zero) this measured level. (typically, a voltage of 100 mV will be measured and try to adjust to less than 5 mV.)

This procedure forces a deliberate degrading of the load regulation to around 0.5%, and will ensure load sharing to within approximately 10%

NOTE: When using Excelsys paralleling links, ensure that the link is assembled with PEM nut located *INSIDE*. Also ensure screw penetration is 4mm maximum.

Current Limit Adjustment (Module 70 only)

Modules 1,2,3,4,5 & 6 have fixed current limits. However, the current limit setpoint is adjustable in Module 70. The standard setting for current limit on Module 70 is 85Amps. Adjustment of this limit is achieved in the range 40A to 85A by adjustment of potentiometer R44 located on the top of the Module 70 surface mount controller card. Adjust counter-clockwise to reduce.

Foldback Current Limit (Module 70 only)

Document no.	Title	Title (Short form)
40001	3Gen and 3Med Series Applications Handbook AN 105	

Revision	Prepared	date	Released	date	Excelsys Technologies Ltd. Swords Business Park, Swords, Co. Dublin, Ireland. (T) +353 1 890 0933 (F) +353 1 890 1358
First	Seamus Devitt	29/05/00	Paul Fenton	27/06/00	
Current	10	Dermot Flynn	13/1/04	NvdW	13/1/04
This document and its contents are the copyright property of Excelsys Technologies Ltd. and may not be copied in whole or in part without written permission.					

Foldback current limit may be implemented by setting of the internal Module70 DIP switch as shown below. Foldback short circuit current = 10% to 25% of I rated (80A).

Remote Module Enable (Module 70 only)

The standard Remote Module Inhibit may be converted to Remote Module Enable by setting of the internal Module 70 DIP switch as shown below.

MODULE 70 DIP Switch Settings

Switch	Factory Setting	Alternative
1	ON Remote Module Inhibit	OFF Remote Module Enable
2	OFF Straight Line Current Limit	ON Foldback Current Limit
3	ON	N/A
4	OFF	N/A

DO NOT CHANGE SETTINGS OF DIP SWITCHES 3 & 4

Output Voltage Adjustment Local vs. Remote Sensing

In certain applications where there is a high dynamic impedance along the power leads to the sensing point; remote sensing may cause system instability. This system problem can be overcome by using resistors in the sense leads (Positive sense lead: R = 100Ω, Negative sense lead: R=10Ω) , together with local AC sensing, by using 22uF capacitors between the remote sense pins and the output terminals. As the output voltage is trimmed, the current limit set-point remains constant. Do not exceed the power supplies maximum rated output power when the module is trimmed up.

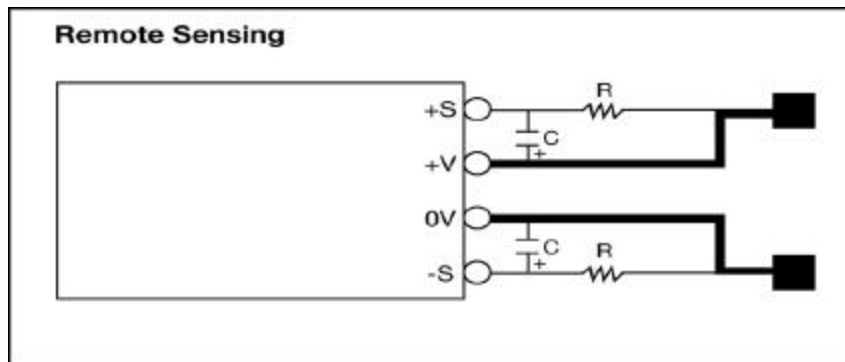

Local Potentiometer Adjustment

Each output has a multi-turn potentiometer for high-resolution adjustment of the output voltage. The adjustment range is as indicated in table (1). All outputs are set to the nominal value unless specifically requested. This may be requested as a standard factory adjustment by means of a configuration sheet (See web site).

Remote Potentiometer Adjustment

Minor adjustment or trimming of the output voltage is possible by means of an external resistor or potentiometer network connected to the margin pin

Document no.	Title	Title (Short form)
40001	3Gen and 3Med Series Applications Handbook AN 105	

Revision	Prepared	date	Released	date	Excelsys Technologies Ltd. Swords Business Park, Swords, Co. Dublin, Ireland. (T) +353 1 890 0933 (F) +353 1 890 1358
First	Seamus Devitt	29/05/00	Paul Fenton	27/06/00	
Current	10 Dermot Flynn	13/1/04	NvdW	13/1/04	Page 15 of 26

This document and its contents are the copyright property of Excelsys Technologies Ltd. and may not be copied in whole or in part without written permission.

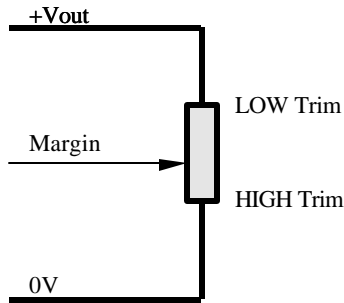

The output voltage can be trimmed HIGH by bringing the margin pin to the lower output voltage rail. Similarly, the output voltage can be trimmed LOW by bringing the margin pin to the higher output rail. Table 1 gives the typical remote adjustments (Control Trim Range) possible through these means.

User Programmable Over Voltage Protection (Not applicable Module 70)

For special applications requiring user programmable setting for the OVP level this can be achieved by connecting a zener diode between the output voltage (cathode) and the module inhibit pin. Choose the value of the zener diode to be approximately 2V less than the desired OVP setting. Certain applications may require a 22uF capacitor to be added between the inhibit pin and common to ensure stability.

Providing Isolation for Output Signals

Module Power Good signal and Output Module Inhibit and may be isolated applications as follows:

Output Module Inhibit

The module may be inhibited by applying between 2 to 5V across A and B. Maximum current drawn at 5V is 10mA, maximum voltage that should be applied is 6V.

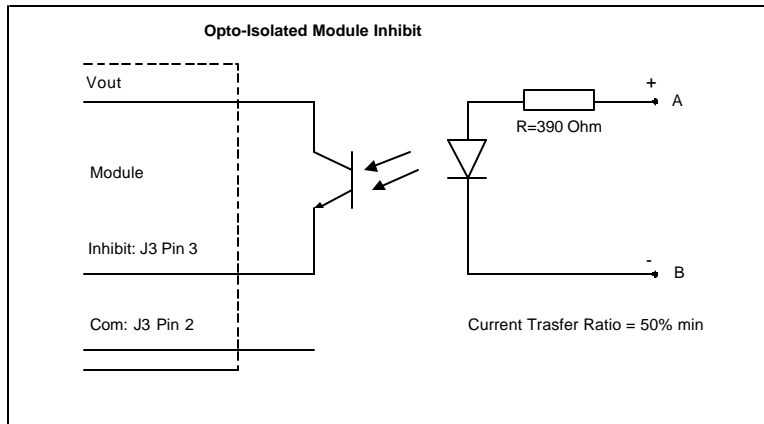

Document no.	Title	Title (Short form)
40001	3Gen and 3Med Series Applications Handbook AN 105	

Revision	Prepared	date	Released	date	Excelsys Technologies Ltd. Swords Business Park, Swords, Co. Dublin, Ireland. (T) +353 1 890 0933 (F) +353 1 890 1358
First	Seamus Devitt	29/05/00	Paul Fenton	27/06/00	
Current	10	Dermot Flynn	13/1/04	NvdW	13/1/04
This document and its contents are the copyright property of Excelsys Technologies Ltd. and may not be copied in whole or in part without written permission.					

Module Power Good

This implementation provides an isolated transistor output which turns off when the output voltage is less than 95% of its set value.

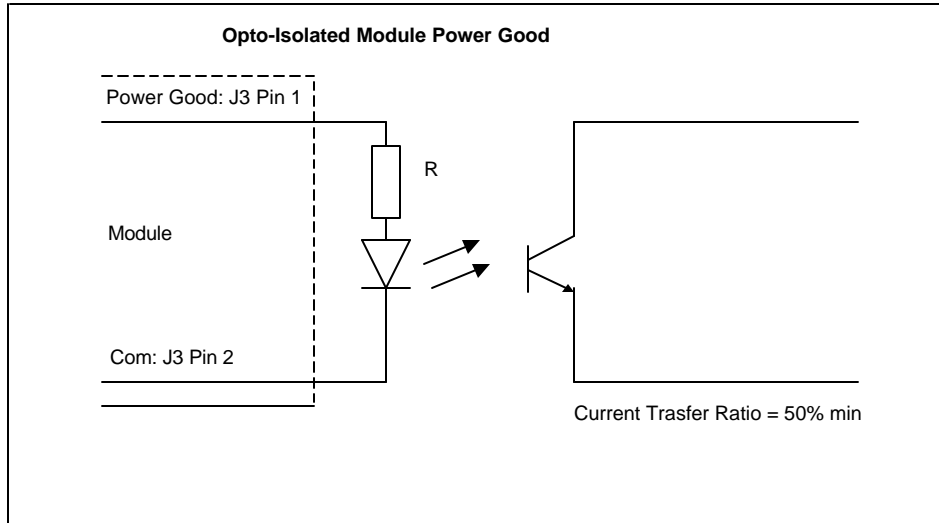

Values of R are dependent on which output modules are in use.

Module	R
Module 1 (3V-5.6V)	1k
Module 2 (5V-13V)	2k
Module 3 (8V-20V)	3k
Module 4 (12V-28V)	5k (0.4W rating)
Module 5 OP 1 (10-28V)	5k (0.4W rating)
Module 5 OP 2 (10-28V)	5k (0.4W rating)
Module 6 OP 1 (3-5.6V)	1k
Module 6 OP 2 (10-28V)	5k (0.4W rating)

The opto-isolated transistor output may be configured as a Common Emitter or Common Collector for multiple applications.

Document no.	Title	Title (Short form)
40001	3Gen and 3Med Series Applications Handbook AN 105	

Revision	Prepared	date	Released	date	Excelsys Technologies Ltd. Swords Business Park, Swords, Co. Dublin, Ireland. (T) +353 1 890 0933 (F) +353 1 890 1358
First	Seamus Devitt	29/05/00	Paul Fenton	27/06/00	
Current 10	Dermot Flynn	13/1/04	NvdW	13/1/04	

This document and its contents are the copyright property of Excelsys Technologies Ltd. and may not be copied in whole or in part without written permission.

6. POWER SUPPLY RELIABILITY

MTBF and Reliability

The 'bath-tub' curve shows how the failure rate of a power supply develops over time. It is made up of three separate parts:

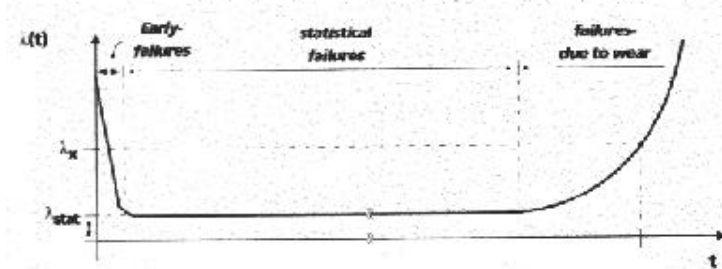

Immediately after production, a relatively high number of units fail due to defective components or production errors. To ensure that these early failures do not happen whilst in the possession of the user, Excelsys carries out a burn-in on each unit, designed to ensure that all these early failures are detected at Excelsys.

After this period, the power supplies fail very rarely, and the failure rate during this period is fairly constant. The reciprocal of this failure rate is the MTBF (Mean Time Between Failures).

At some time, as the unit approaches its end of life, the first signs of wear appear and failures become more frequent. Generally 'lifetime' is defined as that time where the failure rate increases to five times the statistical rate from the flat portion of the curve.

In summary, the MTBF is a measurement of how many devices fail in a period of time (i.e. a measure of reliability), before signs of wear set in. On the other hand, the lifetime is the time after which the units fail due to wear appearing.

The MTBF may be calculated mathematically as follows:

$MTBF = \lambda_{total} \cdot \Delta t / \lambda_{failure}$, where λ_{total} is the total number of power supplies operated simultaneously, $\lambda_{failure}$ is the number of failures, and Δt is the observation period.

MTBF may be established in two ways, by actual statistics on the hours of operation of a large population of units, or by calculation from a known standard such as MIL-HDBK-217 and its revisions.

Determining MTBF by Calculation

MTBF, when calculated in accordance with MIL-HDBK-217, involves the summation of the failure rates of each individual component at its operating temperature. The failure rate of each component is determined by multiplying a base failure rate for that component by its operating stress level. The result is λ_n , the failure rate per million operating hours for that component. Then

$$\lambda = \lambda_1 + \lambda_2 + \dots + \lambda_n$$

$$MTBF \text{ (hours)} = 1,000,000 / \lambda$$

In this manner, MTBF can be calculated at any temperature. The 3gen 4Slot series has been designed to

Document no.	Title	Title (Short form)
40001	3Gen and 3Med Series Applications Handbook AN 105	

Revision	Prepared	date	Released	date	Excelsys Technologies Ltd. Swords Business Park, Swords, Co. Dublin, Ireland. (T) +353 1 890 0933 (F) +353 1 890 1358
First	Seamus Devitt	29/05/00	Paul Fenton	27/06/00	
Current	10	Dermot Flynn	13/1/04	NvdW	13/1/04

Page 18 of 26

This document and its contents are the copyright property of Excelsys Technologies Ltd. and may not be copied in whole or in part without written permission.

Excelsys Technologies Ltd.

achieve an MTBF figure of 150,000hours at 40deg. C. Calculations based on MIL-HDBK-217 result in a figure of approximately 176,000 hours.

Typically, large electrolytic capacitors are a significant factor in causing reduction of the MTBF of switched mode power supplies. For this reason, use of high reliability capacitors is an important design issue in ensuring high MTBF figures for power supplies. This also explains why high-density DC/DC converters achieve apparently very high MTBF figures, up to 1,000,000 hours. The reality, however, is that when the obligatory external bulk capacitors are added, the MTBF figures are reduced to levels consistent with other fully integrated AC/DC power supplies.

Determining MTBF experimentally

MTBF may also be determined from field data. Excelsys verifies its calculated figures by means of extended observation over a large sample of units operating under specific conditions. The results of 3gen power supply reliability testing are outlined below;

Number of Sample Units	80	
Power Supply Part Number	3G4C4400-00	
Ambient Temperature	40 degrees (35 to 45)	
Input Voltage:	115VAC	
Input Frequency:	50Hz	
Output Ratings:	24V @ 12A	
	24V @ 12A	
Output Loadings:	24V @ 10A	
	24V @ 10A	
Total Output Power	480Watts (80% Loading)	
Start date of MTBF Test Period:	11th January, 2000	
End date of MTBF Test Period	11th January, 2002	
Total Hours of MTBF Test	17,520 Hours	
Number of Failures	3	
MTBF	80. 17520 / 3 =	467,200 hours

MTBF and Temperature

Reliability and MTBF are highly dependent on operating temperature. The figures above are given at 40 degrees C. For each 10 degrees decrease, the MTBF increases by a factor of approximately 2.5. Conversely, however, for each 10degrees increase, the MTBF reduces by a similar factor. Therefore, when comparing manufacturer's quoted MTBF figures, look at the temperature information provided.

Document no.	Title	Title (Short form)
40001	3Gen and 3Med Series Applications Handbook AN 105	

Revision	Prepared	date	Released	date	Excelsys Technologies Ltd. Swords Business Park, Swords, Co. Dublin, Ireland. (T) +353 1 890 0933 (F) +353 1 890 1358
First	Seamus Devitt	29/05/00	Paul Fenton	27/06/00	
Current 10	Dermot Flynn	13/1/04	NvdW	13/1/04	
This document and its contents are the copyright property of Excelsys Technologies Ltd. and may not be copied in whole or in part without written permission.					Page 19 of 26

7. SAFETY STANDARDS

The 3gen Series of units is designed to comply with the requirements of IEC950, EN60950, UL1950, CSA 22.2 No. 234 and IEC 1010, when correctly installed in a limited access environment. The 3med Series of units is designed to comply with the requirements of IEC601-1, EN60601-1, UL2601-1 and CSA601-1, for non-patient connect applications.

Modules 2, 3, 4 and 70 are capable of providing hazardous energy levels (>240 VA). Equipment manufacturers must provide adequate protection to service personnel.

Environmental Parameters

The 3gen and 3med series are designed for the following parameters:

- Material Group IIIb, Pollution Degree 2
- Installation Category 2
- Class I
- Indoor use (as part of another piece of equipment, accessible to Service Engineers only).
- Altitude: -155 metres to +3050 metres from sea level.
- Humidity: 10 to 95% non-condensing.
- Operating temperature -20°C to 50°C
- Derate at 2.5%/°C from 50°C to 70°C.

Approval Limitations

Use in North America

When this product is used on 180 to 253 Volts AC mains with no neutral, connect the two live wires to L (live) and N (neutral) terminals on the input connector.

Module Limitations (For UL1950, CSA 22.2 No. 234, and EN60950)

1. Module 1 may be used in slots A, B and C Only
2. Module 70 (uses 2 slots) may be used in slots A& B only.
3. Maximum number of type 1 modules permissible, 3gen4 & 3gen6 units is 2 and 3 respectively.
4. Only one module of type 70 is permissible in any unit.

IMPORTANT: Operation of the modules outside the above limitations invalidates Safety Agency approval.

Creepage Distances 3gen Series

- Primary mains circuits to earth: 2.5mm spacing
- Primary mains circuits to secondary: 5mm spacing

Creepage Distances 3med Series

- Primary mains circuits to earth: 4mm spacing
- Primary mains circuits to secondary: 8mm spacing

Dielectric strength 3gen Series

- Primary mains circuits to chassis: 1500VAC
- Primary mains circuits to secondary: 3000VAC

Dielectric strength 3med models

- Primary mains circuits to chassis: 1500VAC
- Primary mains circuits to secondary: 4000VAC

The primary to secondary test is not possible with modules fitted to the unit, as damage to the RFI capacitors will occur.

Output Isolation

Outputs are each isolated 100 Volts DC to each other and 500 Volts to chassis.

Document no.	Title	Title (Short form)
40001	3Gen and 3Med Series Applications Handbook AN 105	

Revision	Prepared	date	Released	date	Excelsys Technologies Ltd. Swords Business Park, Swords, Co. Dublin, Ireland. (T) +353 1 890 0933 (F) +353 1 890 1358
First	Seamus Devitt	29/05/00	Paul Fenton	27/06/00	
Current	10	Dermot Flynn	13/1/04	NvdW	13/1/04
This document and its contents are the copyright property of Excelsys Technologies Ltd. and may not be copied in whole or in part without written permission.					

8. SAFETY, REGULATORY & EMI SPECIFICATIONS

Low Voltage Directive (LVD) 73/23/EEC

The LVD applies to equipment with an AC input voltage of between 50V and 1000V or a DC input voltage between 75V and 1500V. The 3gen and 3med Series is CE marked to show compliance with the LVD. The relevant European Standard for 3gen series used in this regard is EN60950 (Information Technology). The relevant European Standard for 3med series used in this regard is EN60601-1 (Medical Devices Directive). With appropriate packaging, the 3gen can also meet the requirements of EN 61010-1 for industrial scientific measuring equipment and process control.

EMC Directive 89/336/EEC

Component Power Supplies such as the 3gen and 3med are not covered by the EMC directive. It is not possible for any power supply manufacturer to guarantee conformity of the final product to the EMC directive, since performance is critically dependent on the final system configuration.

System compliance with the EMC directive is facilitated by 3gen and 3med compliance with several of the requirements as outlined in the following paragraphs. Although the 3gen and 3med product series meet these requirements, the CE mark does not cover this area.

EMISSIONS

Power Factor (Harmonic) Correction

The 3gen and 3med series incorporates active power factor correction and therefore meets the requirements of EN61000-3-2, as demonstrated by the test results set out below.

EN61000-3-2 3gen Harmonic Currents (typical)

Results taken at 570W Output Power

	115V AC In		230V AC In	
Harmonic 1	6.420A	100%	3.030A	100%
Harmonic 3	0.103A	1.6%	0.128A	4.2%
Harmonic 5	0.112A	1.7%	0.106A	3.5%
Harmonic 7	0.042A	0.7%	0.014A	0.5%
Harmonic 9	0.067A	1.0%	0.062A	2.0%
Harmonic 11	0.052A	0.8%	0.078A	3.5%
Harmonic 13	0.044A	0.7%	0.064A	2.1%
Efficiency	80.8%		83.7%	

EN61000-3-3 Flicker & Voltage Fluctuation Limits

3gen and 3med power supplies meet the requirements of the limits on voltage fluctuations and flicker in low voltage supply systems.

EN55022 Class B Conducted Emissions

3gen Series

Under appropriate test conditions, the 3gen series meets the requirements of EN55022 Class B, without the need for external filtering.

3med series.

3M4E, 3M6C and 3M6D series meet the requirements of EN55022 Class B, without the need for external filtering.

3M4B, 3M4C, meet the requirements of EN55022 Class B, with the external filter as detailed in section 2)

Document no.	Title	Title (Short form)
40001	3Gen and 3Med Series Applications Handbook AN 105	

Revision	Prepared	date	Released	date	Excelsys Technologies Ltd. Swords Business Park, Swords, Co. Dublin, Ireland. (T) +353 1 890 0933 (F) +353 1 890 1358
First	Seamus Devitt	29/05/00	Paul Fenton	27/06/00	
Current	10	Dermot Flynn	13/1/04	NvdW	13/1/04
This document and its contents are the copyright property of Excelsys Technologies Ltd. and may not be copied in whole or in part without written permission.					
Form name: Controlled Document Template (Con_Doc_Template);10001 rev.00					

IMMUNITY

The 3gen and 3med Series have been designed to meet, and tested to, the immunity specifications outlined below:

EN61000-4-2 Electrostatic Discharge Immunity Test

Level 4
 8kV Air discharge applied to Enclosure
 6kV Contact with Enclosure

EN61000-4-3 Radiated Electromagnetic Field Immunity Test

Level 3
 10Volts/metre 26 to 1000Mhz applied to Enclosure

EN61000-4-4 Fast Transients–Burst Immunity Test (Common Mode)

Level 4
 4kV, 2.5kHz Repetition, Burst period 300ms

EN61000-4-5 Input Surge Immunity Test

Level 3
 +/-2kV Common Mode 1.2/50µS (Voltage); 8/20µS (Current)
 +/- 1kV Differential Mode 1.2/50µS (Voltage) 8/20 µS (Current)

Document no.	Title	Title (Short form)
40001	3Gen and 3Med Series Applications Handbook AN 105	

Revision	Prepared	date	Released	date	Excelsys Technologies Ltd. Swords Business Park, Swords, Co. Dublin, Ireland. (T) +353 1 890 0933 (F) +353 1 890 1358
First	Seamus Devitt	29/05/00	Paul Fenton	27/06/00	
Current 10	Dermot Flynn	13/1/04	NvdW	13/1/04	

This document and its contents are the copyright property of Excelsys Technologies Ltd. and may not be copied in whole or in part without written permission.

9. Connectors

J1 Mains Input Connector		
Pin		
1	Live	LHS
2	Earth	Centre
3	Neutral	RHS
Beau Terminal, 71803-C, Max Torque 1.5Nm		

J2 Primary Input Options		
Pin	Option 03 (Enable)	Option 05 (Inhibit)
1	Enable Negative (diode cathode)	Inhibit Negative (diode cathode)
2	Enable Positive (diode anode)	Inhibit Positive (diode anode)
3	Mains Fail Positive (Collector)	Mains Fail Positive (Collector)
4	Mains Fail (Negative)	Mains Fail (Negative)
Molex: Mating Connector 50-37-5043, pin 08-70-1040		

J2 Primary Input Options		
Pin	Option 06 (Enable)	Option 07 (Inhibit)
1	Bias Supply 5V SELV Output	Bias Supply 5V SELV Output
2	Enable Input	Inhibit Input
3	Mains Fail Positive (Collector)	Mains Fail Positive (Collector)
4	Mains Fail COM	COM
Molex: Mating Connector 50-37-5043, pin 08-70-1040		

Document no.	Title	Title (Short form)
40001	3Gen and 3Med Series Applications Handbook AN 105	

Revision	Prepared	date	Released	date	Excelsys Technologies Ltd. Swords Business Park, Swords, Co. Dublin, Ireland. (T) +353 1 890 0933 (F) +353 1 890 1358
First	Seamus Devitt	29/05/00	Paul Fenton	27/06/00	
Current 10	Dermot Flynn	13/1/04	NvdW	13/1/04	Page 23 of 26

This document and its contents are the copyright property of Excelsys Technologies Ltd. and may not be copied in whole or in part without written permission.

Excelsys Technologies Ltd.

J3 Output Signals Connector		
Pin	Modules 1, 2, 3,4, 5, 6	Module 70
1	Module Power Good	Positive Sense
2	Common	Negative Sense
3	Remote Inhibit	+5V Bias (25mA max.)
4	Margin	Margin
5	N/A	Remote Inhibit/Enable
6	N/A	Module Power Good
Modules 1,2,3,4,5,6. Molex: Mating Connector 50-37-5043, pin 08-70-1040. Excelsys Part Number OPCONN4		
Module 70. Molex Mating Connector 50-37-563, pin 08-70-1040 Excelsys Part Number OPCONN6		

J4 Module Power Output Connectors			
Terminal	Modules 1,2,3,4,	Modules 5,6	Module 70
1 (Top)	Positive Sense	O/P 1 Positive Power	Positive Power
2	Positive Power	O/P 1 Negative Power	Negative Power
3	Negative Power	O/P 2 Positive Power	N/A
4	Negative Sense	O/P 2 Negative Power	N/A
Modules 1, 2, 3, 4, 5, 6: BEAU terminal connector: #6-32 screw terminals. Torque 1.5 Nm Module 70: M6 by 10mm threaded stud, Nut, flat, and lock washers fitted. Torque 3.5Nm			

Document no.	Title	Title (Short form)
40001	3Gen and 3Med Series Applications Handbook AN 105	

Revision	Prepared	date	Released	date	Excelsys Technologies Ltd. Swords Business Park, Swords, Co. Dublin, Ireland. (T) +353 1 890 0933 (F) +353 1 890 1358
First	Seamus Devitt	29/05/00	Paul Fenton	27/06/00	
Current 10	Dermot Flynn	13/1/04	NvdW	13/1/04	
This document and its contents are the copyright property of Excelsys Technologies Ltd. and may not be copied in whole or in part without written permission.					Page 24 of 26

10. Mechanical Drawings

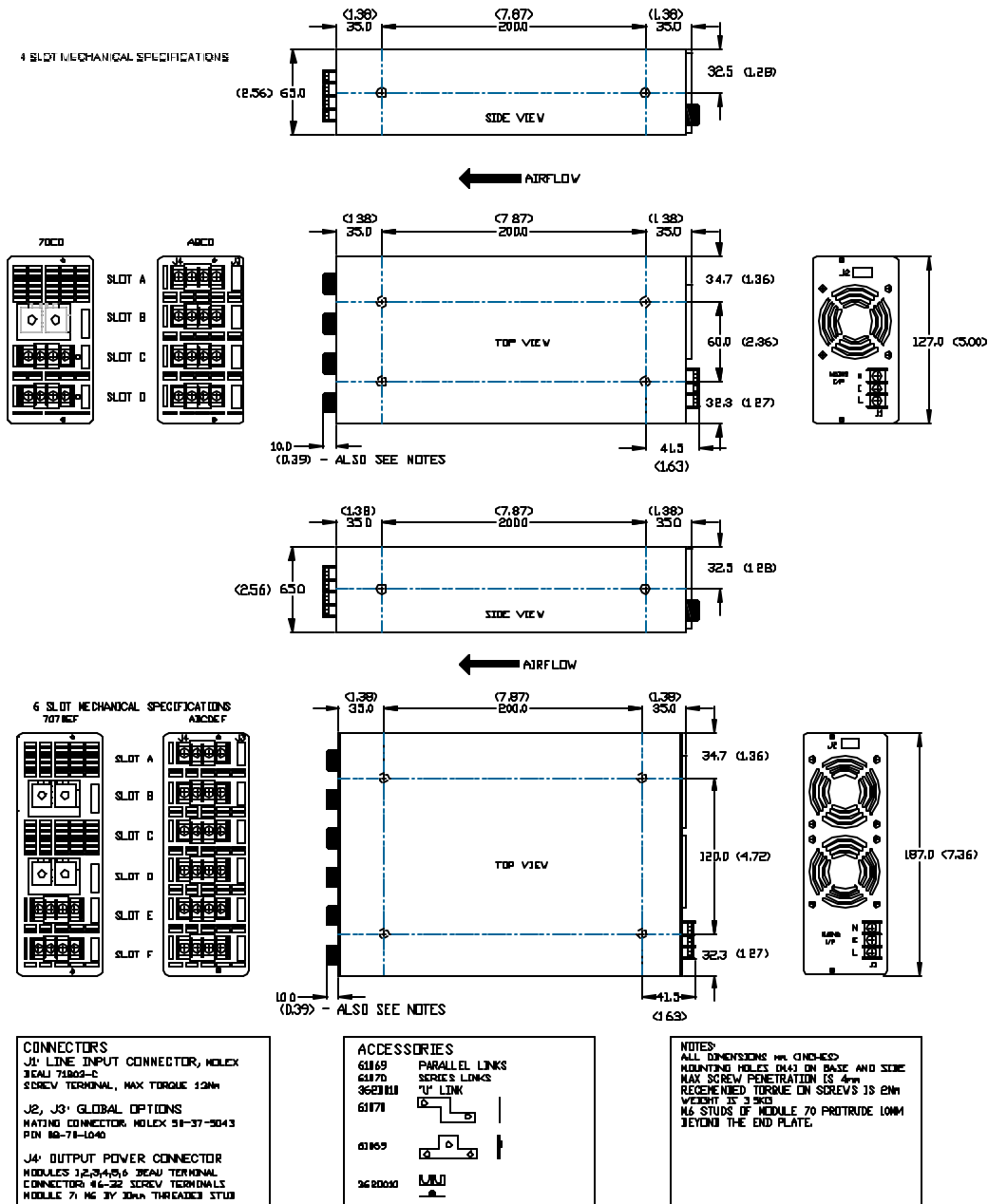

Reference Drawing – 61330r00

Document no.	Title	Title (Short form)
40001	3Gen and 3Med Series Applications Handbook AN 105	

Revision	Prepared	date	Released	date	Excelsys Technologies Ltd. Swords Business Park, Swords, Co. Dublin, Ireland. (T) +353 1 890 0933 (F) +353 1 890 1358
First	Seamus Devitt	29/05/00	Paul Fenton	27/06/00	
Current	10 Dermot Flynn	13/1/04	NvdW	13/1/04	Page 25 of 26

This document and its contents are the copyright property of Excelsys Technologies Ltd. and may not be copied in whole or in part without written permission.

11. 3gen Configuration Rules

The following configuration rules apply in using a 3gen unit.

- 1. Restrictions on Slot Usage (4 Slot Package)**
 - 1.1 Module 1 may be used in slots A, B or C only
 - 1.2 Module 6 may be used in slots B and C only
 - 1.3 Module 70 may be used in slots AB only

- 2. Restrictions on Slot Usage (6 Slot Package)**
 - 2.1 Module 1 may be used in slots A, B , or C only
 - 2.2 Module 6 may be used in slots B,C,D and E only
 - 2.3 Module 70 may be used in slots AB,CD only

- 3. Paralleling Modules**
 - 3.1 Only parallel outputs of the same type
 - 3.2 Use local sensing only
 - 3.3 When outputs are paralleled, derate total current by 10%
 - 3.4 If paralleling is performed locally, use 2 x 61069 paralleling bars for each additional module
 - 3.5 Factory assistance is required to use output option signals with paralleled outputs

- 4. Seriesing Modules**
 - 4.1 Preferably series modules of the same type
 - 4.2 When outputs are seriesed, the resultant output voltage will not meet SELV requirements
 - 4.3 If adjacent modules are seriesed, use 1 x 61070 series bar for each additional module
 - 4.4 If the outputs of a dual module are seriesed, use 1 x 362D010 Series 'U' link
 - 4.5 Factory assistance is required to use output option signals with seriesed modules

- 5. Combining Modules for Higher Power**
 - 5.1.1 Where two modules are used to generate a required voltage & current, use modules in parallel in preference to modules in series

- 6. Power Rating Check**

Actual Output Power = The sum of **Actual Volts x Actual Amps** for each output
 Nominal Output Power = The sum of **Nominal Volts x Actual Amps** for each output
 Nominal Output Power **must be less** than the Power Rating of the Input Module

- 7. Filling of Slots**
 - 7.1 The default methodology is to fill slots with modules in ascending numerical order from A to D (or F). For example, 3G4C1234-00 rather than 3G4C2134-00. Note module 70 is an exception to this rule.

Whilst every effort has been made to ensure the accuracy of the contents of this handbook, Excelsys Technologies Ltd. cannot accept any liability for errors contained herein.
 Excelsys operates a policy of Continuous Product Improvement, and specifications are subject to change without prior notice. 22/05/03

Document no.	Title	Title (Short form)
40001	3Gen and 3Med Series Applications Handbook AN 105	

Revision	Prepared	date	Released	date	Excelsys Technologies Ltd.	
First	Seamus Devitt	29/05/00	Paul Fenton	27/06/00		Swords Business Park, Swords, Co. Dublin, Ireland. (T) +353 1 890 0933 (F) +353 1 890 1358
Current	10	Dermot Flynn	13/1/04	NvdW	13/1/04	Page 26 of 26

This document and its contents are the copyright property of Excelsys Technologies Ltd. and may not be copied in whole or in part without written permission.