

## EMI

**Abstract:** This paper looks at the Electro Magnetic Interference (EMI) sources on a power supply, and how Excelsys applies its knowledge of these issues to design low profile performance leading EMI designs.

### 1.0 Introduction:

EMI is everywhere. Even mother nature provides many sources of electromagnetic interference, and our own sun is a source of much radiation on a daily basis. However for electrical equipment we usually only have to deal with man made sources of radiation. These can be intentional such as radio, TV, telephony and RF, or they can be unintentional (sources can appear as a result of load distribution, vehicle ignition systems and even power supplies!). This paper will address some of these unintentional sources and more importantly how to eliminate them.

### 2.0 What is it about power supplies that makes them such noisy sources?

Any source of changing voltage or changing current with respect to time will result in ringing. Any given switch mode power supply will be full of these events occurring every switching cycle. All tracks, points and components are a potential source of this on a power supply. But the hidden truth is that most EMC sources do not appear on any bill of materials. So what do we mean by this statement?

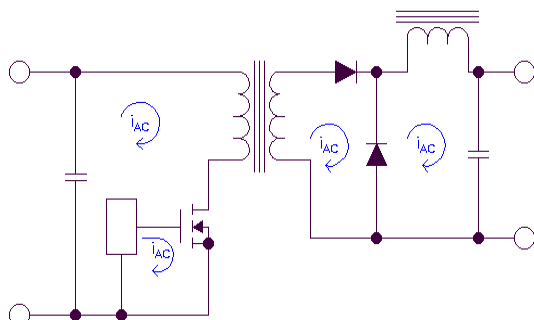

**Figure 1:** High di/dt loops on a forward convertor.

Within any given design there will be loops with high di/dt and high dv/dt's. Figure 1 above identifies the potential areas for high di/dt's in an isolated forward convertor, while figure 2 shows

the potential areas for high dv/dt's in the same design.

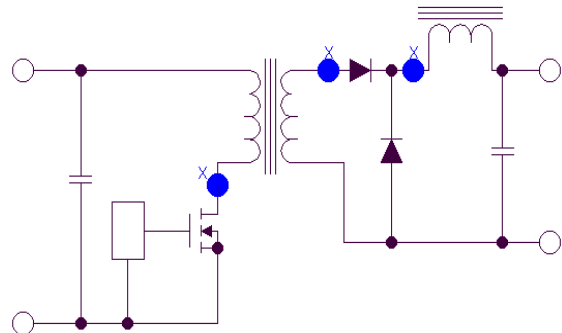

**Figure 2:** High dv/dt areas on a forward convertor.

With such high di/dt's and dv/dt's it doesn't take much interwinding capacitance to generate significant common mode currents and voltage spikes of up to several volts. This will result in ground bounce, and hence EMI.

If we continue with this path of investigation we can also look at the example of a FET going from a Vds of 200 Volts in 40nS. This equates to a dv/dt of 5 billion volts per second !

### 3.0 How to design to minimise emissions.

Designing power supplies for good EMI performance is not a black magic. With the correct knowledge and experience, limiting EMI can be accommodated right from the project concept stage. This includes a heavy focus on the design and layout of the PCB, as this will play a significant role in emissions.

The first focus for any designer is to eliminate or at least minimise the emissions from the source of the generators. Also remember that receivers re-transmit, so minimise the susceptibility of receivers. If this is still not achieving the target emissions then as a final solution you may need to look at filters, but it should be remembered that filters can result in significant addition of real estate to your final design.

### 3.1 How PCB layout plays its part.

PCB layout is often the least understood when it comes to designing for EMI. But it need not be a difficult thing to if you keep the following items in mind.

1. Minimise loop areas.
2. Leave no floating parts, ensuring that all loops are brought back to ground.
3. Keep signal and power ground connections separate.

This will add to the complexity of the PCB design so there are normal compromises in order to save on layers. On one layer you should track the input and output signal grounds with the star points at the IC's common pins (allow for the isolation barrier between input and output). On a separate layer the ground plane for the power grounds. Input ground plane under the input components only, output ground plane under the output components only, allow for the isolation barrier between input and output ground planes

Also, remember that earthing schemes were designed for safety purposes, not EMI, so use ground planes and short connections. Also there should be only one connection between signal and power grounds, through a via at the signal ground star point.

### 3.2 Consider your components with respect to frequency:

The difficulty facing power supply designers is that EMI performance is not usually characterised by the component manufacturer. Understanding your components is key to knowing how they will behave in terms of emissions. This is especially true at the highest effective frequency. You must also consider that things like capacitors, wire wound resistors and even wire leads will vary in behaviour as the frequency changes. This also holds true for the type of capacitors used, as tantalum capacitors behave differently to say ceramic capacitors. Your parasitic components, ESR, ESL, Cs and leakage will all play their part, so knowing and quantifying these are all key to understanding EMI.

Most EMC components are invisible on the circuit diagram and are either stray and parasitic components everything must be done with sound RF principles in mind.

### 4.0 Xgen performance

The Xgen is a series of user configurable power supplies with innovative Plug and Play architecture. This allows system designers an unprecedented flexibility providing instant power supply solutions.

- High Efficiency 90%
- Low Profile 1U
- Power Density 16W/in<sup>3</sup>
- Plug and Play Power

Our products have been tailored to address the specific requirements of the application including:

- Industrial Electronics
- Medical Electronics
- Low Acoustic Noise applications
- High Temperature Applications



The Xgen has been designed to meet Class B emissions, and incorporates all of the issues discussed on this paper. The Xgen also incorporates many other EMI considerations that make it a very robust power supply for many applications. Some of these features are

- Active power factor correction and therefore meets the requirements of EN61000-3-2. It also has a Power factor of 0.98 over all line and load conditions.
- Flicker & Voltage Fluctuation Limits. Meets the requirements of the limits on voltage fluctuations and flicker in low voltage supply systems as defined by EN61000-3-3.

- EN55022 Class B Conducted Emissions Under appropriate test conditions, the Xgen series meets the requirements of EN55022 Class B, without the need for external filtering.

The Xgen series has also been designed to meet the immunity specifications outlined below:

- EN61000-4-2 Electrostatic Discharge Immunity. 8kV Air discharge applied to Enclosure. 6kV Contact with Enclosure
- EN61000-4-3 Radiated Electromagnetic Field 10Volts/metre 80MHz to 2.5GHz applied to Enclosure
- EN61000-4-4 Fast Transients-Burst Immunity +/-2kV
- EN61000-4-5 Input Surge Immunity +/- 2kV Common Mode 1.2/50 S (Voltage); 8/20uS (Current) +/- 1kV Differential Mode 1.2/50 S (Voltage) 8/20 S (Current)
- EN61000-4-6 Conducted Immunity 10 V/m 150KHz to 80MHz EN61000-4-11 Voltage Dips

#### **5.0 So my power supply meets Class B, are there any more issues I need to consider?**

Compliance of the power supply in a test house to various limits does not necessarily guarantee the user that it will pass when installed into a system. There are a number of causes of poor system noise performance. Some of these are listed below.

- Insufficient de-coupling on the PCB or load
- Faulty wiring connection or poor cable terminations
- Poor system earthing

There are some simple steps to eliminate, reduce or identify the causes of high frequency noise

- Is the noise conducted or radiated? If changing the position of the power supply or screening improves performance, the noise is likely to be radiated.
- Twist all pairs of power and sense cables separately
- Ground connections (zero Volt) should be made to the nearest point on the chassis.

In the same way that the power supply designer needs to ensure that the sources for radiation are kept to a minimum, the system designer also has a role to play in ensuring that the overall system has the optimum performance. Cabling arrangements

and PCB tracking layouts are the greatest contributing factor to system EMC performance. It is important that PCB tracks and power cables are arranged to minimise current carrying loops that can radiate, and to minimise loops that could have noise currents induced into them. All cables and PCB tracks should be treated as radiation sources and antennae and every effort should be made to minimise their interaction

- Keep all cable lengths as short as possible.
- Minimise the area of power carrying loops to minimise radiation, by using twisted pairs of power cables with the maximum twist possible.
- Run PCB power tracks back to back.
- Minimise noise current induced in signal carrying lines, by twisted pairs for sense cables with the maximum twist possible.
- Do not combine power and sense cables in the same harness
- Ensure good system grounding. System Earth should be a “starpoint”. Input earth of the equipment should be directed to the “starpoint” as soon as possible. The power supply earth should be connected directly to the “starpoint”. All other earths should go to the ‘starpoint’

#### **6.0 Summary**

Electro Magnetic Interference is considered by many as being a black art, but the truth of the matter is that with sufficient knowledge, due diligence and attention to detail you can design your power supply to have the optimum performance. Trying to address this issue at the back end of a design process can be costly, time consuming, and end up having to use relatively large filters. Power supplies by their nature are noisy environments, but taking every aspect of the design into consideration a market leading performance is achievable. Reduce your common mode impedances, know your components, and layout your PCB correctly at the beginning of your design cycle. This will minimise your troubleshooting EMI problems later. Above all remember that EMI design is the sum of many small items, and only when *all* of these are addressed will you see improvements in the emissions.

*Excelsys Technologies Ltd. is a modern world-class power supplies design company providing quality products to OEM equipment manufacturers around the world. This is achieved by combining the latest technology, management methods and total customer service philosophy with a 20 year tradition of reliable and innovative switch mode power supply design, manufacture and sales. If there are any further points you wish to discuss from this paper please contact [support@excelsys.com](mailto:support@excelsys.com). Further information on our products can also be found at [www.excelsys.com](http://www.excelsys.com)*